



Estd: 2008

METHODIST

COLLEGE OF ENGINEERING & TECHNOLOGY

UGC AUTONOMOUS Institution Affiliated to Osmania University, Accredited
by NBA & Naac with A+

Abids, Hyderabad, Telangana, 500001

DEPARTMENT OF MECHANICAL ENGINEERING

LABORATORY MANUAL

HEAT TRANSFER LABORATORY

**BE VI Semester
AUTONOMOUS**

Name:

Roll No:

Branch:.....SEM:.....

Academic Year:

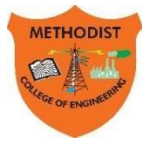

Estd: 2008

METHODIST

COLLEGE OF ENGINEERING & TECHNOLOGY

Approved by AICTE New Delhi | Affiliated to Osmania University, Hyderabad
Abids, Hyderabad, Telangana, 500001

VISION

To produce ethical, socially conscious and innovative professionals who would contribute to sustainable technological development of the society.

MISSION

To impart quality engineering education with latest technological developments and interdisciplinary skills to make students succeed in professional practice.

To encourage research culture among faculty and students by establishing state of art laboratories and exposing them to modern industrial and organizational practices.

To inculcate humane qualities like environmental consciousness, leadership, social values, professional ethics and engage in independent and lifelong learning for sustainable contribution to the society.



Estd: 2008

METHODIST

COLLEGE OF ENGINEERING & TECHNOLOGY

Approved by AICTE New Delhi | Affiliated to Osmania University, Hyderabad

Abids, Hyderabad, Telangana, 500001

DEPARTMENT OF MECHANICAL ENGINEERING

LABORATORY MANUAL

HEAT TRANSFER LABORATORY

(6PC659ME)

Prepared by

Dr. M. Prasad, Assistant Professor. Mech. Engg.

Mr. Y. Madhu Maheswara Reddy, Assistant Professor. Mech. Engg.

DEPARTMENT OF MECHANICAL ENGINEERING

VISION

To be a reputed centre of excellence in the field of mechanical engineering by synergizing innovative technologies and research for the progress of society.

MISSION

- To impart quality education by means of state-of-the-art infrastructure.
- To involve in trainings and activities on leadership qualities and social responsibilities.
- To inculcate the habit of life-long learning, practice professional ethics and service the society.
- To establish industry-institute interaction for stake holder development.

DEPARTMENT OF MECHANICAL ENGINEERING

After 3-5 years of graduation, the graduates will be able to:

PEO1: Excel as engineers with technical skills, and work with complex engineering systems.

PEO2: Capable to be entrepreneurs, work on global issues, and contribute to industry and society through service activities and/or professional organizations.

PEO3: Lead and engage diverse teams with effective communication and managerial skills.

PEO4: Develop commitment to pursue life-long learning in the chosen profession and/or progress towards an advanced degree

DEPARTMENT OF MECHANICAL ENGINEERING

PROGRAM OUTCOMES

Engineering Graduates will be able to:

PO1. Engineering knowledge: Apply the basic knowledge of mathematics, science and engineering fundamentals along with the specialized knowledge of mechanical engineering to understand complex engineering problems.

PO2. Problem analysis: Identify, formulate, design and analyse complex mechanical engineering problems using knowledge of science and engineering.

PO3. Design/development of solutions: Develop solutions for complex engineering problems, design and develop system components or processes that meet the specified needs with appropriate consideration of the public health and safety, and the cultural, societal, and environmental considerations.

PO4. Conduct investigations of complex problems: Formulate engineering problems, conduct investigations and solve using research-based knowledge.

PO5. Modern tool usage: Use the modern engineering skills, techniques and tools that include IT tools necessary for mechanical engineering practice.

PO6. The engineer and society: Apply the contextual knowledge to assess societal, health, safety, legal and cultural issues and the consequent responsibilities relevant to the professional engineering practice.

PO7. Environment and sustainability: Understand the impact of the professional engineering solutions in societal and environmental contexts, and demonstrate the knowledge of, and need for sustainable development.

PO8. Ethics: Apply ethical principles and commit to professional ethics and responsibilities during professional practice.

PO9. Individual and team work: Function effectively as an individual, and as a member or leader in diverse teams, and in multidisciplinary settings.

PO10. Communication: Communicate effectively on complex engineering activities to various groups, ability to write effective reports and make effective presentations.

PO11. Project management and finance: Demonstrate and apply the knowledge to understand the management principles and financial aspects in multidisciplinary environments.

PO12. Life-long learning: Recognize the need for, and have the preparation and ability to engage in independent and life-long learning in the broadest context of technological change.

PROGRAM SPECIFIC OUTCOMES

Mechanical Engineering Graduates will be able to:

PSO1: Apply the knowledge of CAD/CAM/CAE tools to analyse, design and develop the products and processes related to Mechanical Engineering.

PSO 2: Solve problems related to mechanical systems by applying the principles of modern manufacturing technologies.

PSO 3: Exhibit the knowledge and skill relevant to HVAC and IC Engines.

CODE OF CONDUCT

1. Students should report to the concerned labs as per the time table schedule.
2. Students who turn up late to the labs will in no case be permitted to perform the experiment scheduled for the day.
3. After completion of the experiment, certification of the concerned staff in-charge in the observation book is necessary.
4. Staff member in-charge shall award marks based on continuous evaluation for each experiment out of maximum 15 marks and should be entered in the evaluation sheet/attendance register.
5. Students should bring a note book of about 100 pages and should enter the readings/observations into the notebook while performing the experiment.
6. The record of observations along with the detailed experimental procedure of the experiment performed in the immediate last session should be submitted and certified by the staff member in-charge.
7. Not more than three students in a group are permitted to perform the experiment on a setup for conventional labs and one student in case of computer labs.
8. The components required pertaining to the experiment should be collected from stores in-charge after duly filling in the requisition form.
9. When the experiment is completed, students should disconnect the setup made by them, and should return all the components/instruments taken for the purpose.
10. Any damage of the equipment or burn-out of components will be viewed seriously either by putting penalty or by dismissing the total group of students from the lab for the semester/year.
11. Students should be present in the labs for the total scheduled duration.
12. Students are required to prepare thoroughly to perform the experiment before coming to Laboratory.

DO'S

1. All the students are instructed to wear protective uniforms, shoes & identity cards before entering into the laboratory.
2. Please follow instructions precisely as instructed by your supervisor.
3. Students should come with thorough preparation for the experiment to be conducted.
4. Students will not be permitted to attend the laboratory unless they bring the practical record fully completed in all respects pertaining to the experiment conducted in the previous class.
5. Practical records should be neatly maintained.
6. Students should obtain the signature of the staff-in-charge in the observation book after completing each experiment.
7. Theory regarding each experiment should be written in the practical record before procedure in your own words.
8. If any laboratory equipment is malfunctioning, making strange noise, sparking, smoke, or smell, inform the instructor or staff immediately. It is imperative that the instructor or staff knows of any equipment problems.

DON'TS

1. Don't operate any machine without getting concerned staff member's prior permission.
2. Using the mobile phones in the laboratory is strictly prohibited.
3. Do not leave the experiments unattended while in progress.
4. Do not crowd around the equipment & run inside the laboratory.
5. Do not wander around the lab and distract other students
6. Do not use any machine that smokes, sparks, or appears defective.

COURSE OBJECTIVES

The objectives of this course are to:

1.	Student will acquire basic knowledge in determining thermal conductivity of a composite slab.
2.	Student will demonstrate basic knowledge in evaluating the heat transfer coefficients under natural convection and forced convection phenomena
3.	Student will determine the necessary constants pertaining to radiation
4.	Student will acquire basic knowledge in understanding the working principles of axial flow fan and its overall efficiency.
5.	Student will come to know in estimating overall efficiency of a centrifugal blower

COURSE OUTCOMES

CO No.	Course Outcomes	PO
CO 1	Analyze the effective thermal resistance in composite slabs and thermal conductivity of metal bar.	1, 2, 3, 4, 6, 11
CO 2	Evaluate the heat transfer coefficient in free and forced convection.	1, 2, 3, 4, 6, 11
CO 3	Evaluate the overall heat transfer coefficient of Parallel and counter flow heat exchanger	1, 2, 3, 4, 6, 11
CO 4	Evaluate emissivity of test plate and Stefan Boltzman constant.	1, 2, 3, 4, 6, 11
CO 5	Analyze overall efficiency of Axial flow fan and Centrifugal blower.	1, 2, 3, 4, 6, 11

COURSE OUTCOMES VS POs MAPPING

S. NO	PO1	PO2	PO3	PO4	PO5	PO6	PO7	PO8	PO9	PO10	PO11	PO12	PSO1	PSO2	PSO3
6PC659ME.1	3.0	3.0	3.0	3.0	-	1.0	-	-	-	-	2.0	-	-	-	-
6PC659ME.2	3.0	3.0	3.0	3.0	-	1.0	-	-	-	-	2.0	-	-	-	-
6PC659ME.3	3.0	3.0	3.0	3.0	-	1.0	-	-	-	-	2.0	-	-	-	-
6PC659ME.4	3.0	3.0	3.0	3.0	-	1.0	-	-	-	-	2.0	-	-	-	3.0
6PC659ME.5	3.0	3.0	3.0	3.0	-	1.0	-	-	-	-	2.0	-	-	-	-
Avg	3.0	3.0	3.0	3.0	-	1.0	-	-	-	-	2.0	-	-	-	3.0

LIST OF EXPERIMENTS

Exp. No.	Experiment Name	Page No.
1.	Determination of overall and individual plate thermal conductivity for a composite wall.	01
2.	Determination of thermal conductivity of metal Rod.	07
3.	Determine heat transfer in pin-fin and its efficiency.	14
4.	Determination of radiation emissivity of a test plate	23
5.	Determination of Stefan-Boltzmann constant for radiation.	30
6.	Determine overall heat transfer coefficient of Parallel and counter flow heat exchanger	37
7.	Determination of COP of Refrigeration system using capillary tube and thermostatic expansion valve	49
8.	Determination of overall efficiency of axial flow fan	55
9.	Determination of overall efficiency of centrifugal blower	63
10.	Measurement of Lift and Drag force models in Wind tunnel section	71 80
11.	Heat transfer in Natural convection	85
12.	Heat transfer in Forced convection	92

EXPERIMENT - 01

HEAT TRANSFER THROUGH COMPOSITE WALL

AIM:

1. To determine total thermal resistance and thermal conductivity of composite wall.
2. To plot temperature gradient along composite wall structure.

THEORY:

The apparatus consists of a cylindrical composite slab made of Aluminium, Brass, Copper . A Nichrome band heater is wrapped around the periphery of the slab at one end to heat the composite slab. A Cooling water jacket is provided on other end of a composite structure. The rods are covered with asbestos rope to prevent heat loss. Rotameter is provided to measure flow rate of water across the water jacket A dimmerstat is provided for varying the input to the heater and measurement of input is carried out by a voltmeter and ammeter. Thermocouples are embedded between interfaces of the slabs, to read the temperature. The experiments can be conducted at various values of input and calculation can be made accordingly.

Specifications

1. Heater: Band heater capacity 400 watt maximum.
2. Heater Control Unit: 0-230V. Ammeter 0-2Amps. Single phase dimmerstat (1No.).
3. Voltmeter 0- 200V. Ammeter 0-2Amps.
4. Temperature Indicator (digital type): 0-200°C. Service required – A. C. single phase 230 V. earthed electric supply.
5. Rota meter 0.2 to 2 LPM
6. Length of Aluminium (L_A) = 100mm
7. Length of Brass (L_B) = 20mm
8. Length of Cast iron(L_C) = 50mm
9. Slab Radius = 25 mm.

PROCEDURE:

1. Start the supply of heater by varying the dimmerstat adjust the input at the desired value.
2. Take readings of all the thermocouples at an interval of 10 minutes until fairly steady temperatures are achieved and rate of rise is negligible.
3. Note down the reading in observation table.

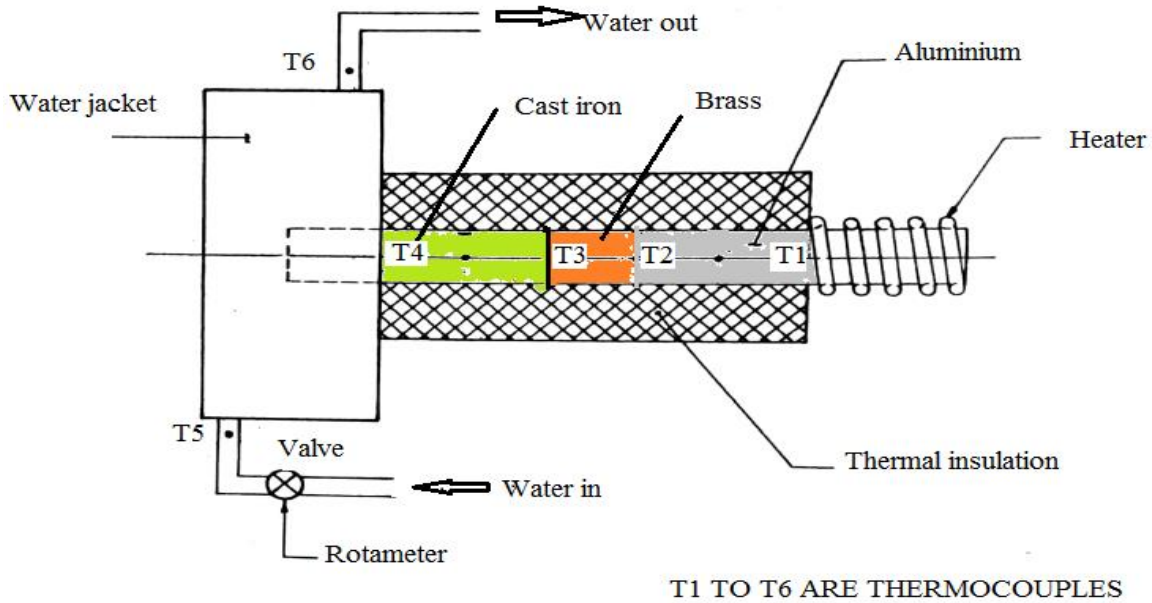

Tabular Column

S.NO	V	I	Q=V*I Watts	T ₁ °C	T ₂ °C	T ₃ °C	T ₄ °C	T ₅ °C Water inlet	T ₆ °C Water out let	Overall Thermal conductivity (K _o) $\frac{w}{mk}$
1										
2										
3										
4										

Temperature difference Readings: $\Delta T_A = T_1 - T_2$

$\Delta T_B = T_2 - T_3$

$\Delta T_C = T_3 - T_4$

Calculations

Read the Heat supplied $Q = V * I$ Watts

$$\text{Heat flux}(q) = \frac{Q}{A} \quad \frac{W}{M^2}$$

Where

$$A = \pi r^2$$

$r =$ Radius of Slab =25mm

1. Total thermal resistance of composite slab

$$R_{\text{TOTAL}} = \frac{\Delta T_A - \Delta T_C}{A * (T_1 - T_4)} \quad ^\circ\text{C/Watt}$$

2. Thermal conductivity of composite slab.

$$K_{\text{COMPOSITE}} = \frac{Q * L}{A * (T_1 - T_4)} \quad \frac{w}{mk}$$

$L =$ Total thickness of composite slab.=170 mm

3 Thermal conductivity of Aluminium ,Brass, Cast iron

$$K_{\text{AL}} = \frac{Q * L_A}{A * (T_1 - T_2)} \quad \frac{w}{mk}$$

$$K_{\text{BR}} = \frac{Q * L_B}{A * (T_2 - T_3)} \quad \frac{W}{mk}$$

$$K_{\text{CI}} = \frac{Q * L_C}{A * (T_3 - T_4)} \quad \frac{w}{mk}$$

2. To plot thickness of slab material against temperature gradient.

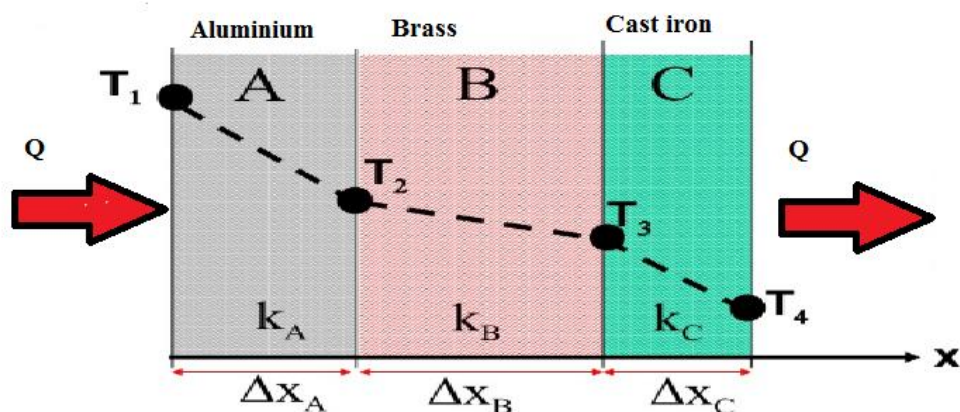

FIG: CONDUCTION THROUGH COMPOSITE WALL

Space For Calculations

RESULT & CONCLUSIONS:

Thermal conductivity of aluminium = $\frac{w}{mk}$

Thermal conductivity of Brass = $\frac{w}{mk}$

Thermal conductivity of Cast iron = $\frac{w}{mk}$

Overall Thermal conductivity = $\frac{w}{mk}$

VIVA QUESTIONS:

1. Define thermal conductivity?
2. For which material thermal conductivity is highest?
3. Why negative sign in Fourier's Law?
4. What are the units of thermal conductivity?
5. What is the first law of thermodynamics?
6. What is the second law of thermodynamics?
7. How is thermal conductivity measured practically?
8. Why are diamonds sinks used in cooling electronic components?
9. What is the physical mechanism of conduction in solids, liquids and gases?
10. What do you mean by " ρc_p "?
11. What is the physical significance of thermal diffusivity?
12. Is heat transfer a scalar or vector quantity?
13. What do you mean by steady heat transfer and how does it differ from transient heat transfer?
14. What is lumped system? How does heat transfer in a lumped system differ from steady heat transfer?
15. How are ordinary and partial differential equations used in heat transfer analysis? 16. What is a boundary condition? Explain.

EXPERIMENT - 02

THERMAL CONDUCTIVITY OF METAL ROD

AIM:

To determine thermal conductivity of metal rod.

THEORY :

Thermal conductivity is the physical property of the material denoting the ease with a particular substance can accomplish the transmission of thermal energy by molecular motion. Thermal conductivity of material is found to depend on the chemical composition of the substance or substance of which it is composed, the phase (i. e. gas, liquid or solid) in which it exists, its crystalline structure if a solid, the temperature and pressure to which it is subjected, and whether or not it is a homogeneous material.

Mechanism of Thermal Energy Conduction In Metals:

Thermal energy may be conducted in solids by two modes :

1. Lattice Vibration.
2. Transport by free electrons.

In good electrical conductors a rather large number of free electrons move about in the lattice structure of the material. Just as these electrons may transport electric charge, they may also carry thermal energy from a high temperature region to a low temperature region. In fact, these electrons are frequently referred as the electron gas. Energy may also be transmitted as vibrational energy in the lattice structure of the material. In general, however, this latter mode of energy transfer is not as large as the electrons transport and it is for this reason that good electrical conductors are almost always good heat conductor viz. Copper, Aluminium and silver. With increase in the temperature, however the increased lattice vibrations come in the way of the transport by free electrons for most of the pure metals the thermal conductivity decreases with increase in the temperature.

The experimental set up consists of the metal bar, one end of which is heated by an electric heater while the other end of the bar projects inside the cooling water jacket. The middle portion of the bar is surrounded by a cylindrical asbestos rope . The temperature of the bar is measured at four different sections. The heater is provided with a dimmerstat for

controlling the heat input. Water is circulated through the jacket and its flow rate and temperature rise are noted.

Specification:

1. Length of the metal bar (total) : 210 mm
2. Size of the metal bar (diameter) : 38 mm
3. No. of thermocouples : 6
4. Heater coil (Band type) : Nichrome.
5. Water jacket diameter : 80mm
6. Temperature indicator.
7. Dimmerstat for heater coil : 2A / 230 V.
8. Voltmeter 0 to 300 volts.
9. Ammeter 0 to 2 Amps.
10. Rotameter for water flow rate

The heater will heat the bar at its end and heat will be conducted through the bar to other end. After attaining the steady state.

Heat flowing out of bar = Heat gained by water

$$Q_w = M_f * C_{p_w} * (T_6 - T_5) = K * A * (\Delta T / \Delta T_x)$$

Where, M_f : Mass flow rate of the cooling water In Kg / Sec

C_{p_w} : Specific Heat of water =4.197Kj/Kg K

Heat conducted through the bar (K)

$$Q = K * A * [\Delta T / \Delta T_x]$$

Where, ΔT =Change in temperature. ($T_1 - T_4$)

ΔT_x : Length.=210 mm

$$\text{Area of the bar} = A = \frac{\pi}{4} * d^2$$

$\frac{\Delta T}{\Delta T_x}$ is obtained from graph

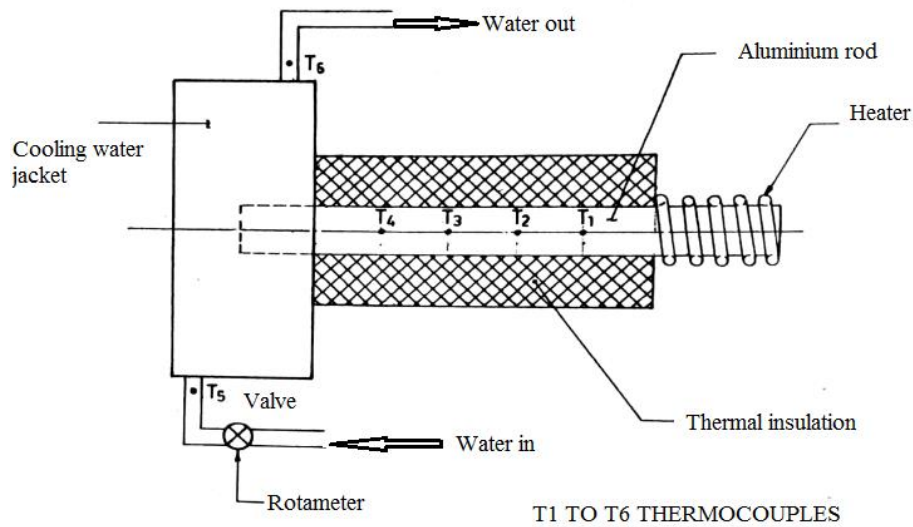

FIG: THERMAL CONDUCTIVITY OF METAL ROD

T₁, T₂, T₃, & T₄ Thermocouples are kept at a distance of 50 mm

PROCEDURE:

Start the electric supply.

1. Adjust the temperature in the temperature indicator by means of rotating the knob for compensation of temperature equal to room temperature. (Normally this is pre adjusted)
2. Give input to the heater by slowly rotating the dimmerstat and adjust it to voltage equal to 80 V, 120 V etc.
3. Start the cooling water supply through the jacket
4. Go on checking the temperature at some specified time interval say 5 minute and continue this till a satisfactory steady state condition is reached.
5. Note the temperature readings
6. Note the mass flow rate of water in Kg/Sec and temperature rise in it.

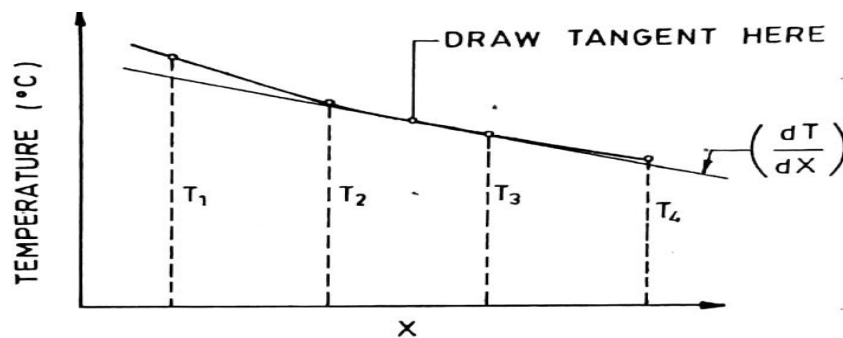

GRAPH: TEMPERATURE VS LENGTH

Tabular column :

S.NO	Mass Flow rate of water Kg/sec (M_f)	T ₁ °C	T ₂ °C	T ₃ °C	T ₄ °C	T ₅ °C Water inlet	T ₆ °C Water out let	Thermal conductivity (K) $\frac{W}{mk}$
1								
2								
3								
4								

Calculations

1. Heat flowing out of bar. = Q_w

$$Q_w = M_f * C_p * (\Delta T_w) \text{ Watts}$$

Where, M_f : Mass flow rate of the cooling water In Kg/Sec

C_p : Specific Heat of water = 4.197 KJ/Kg K

$$\Delta T_w = (T_5 - T_6)$$

2. Thermal conductivity of Bar (K)

$$K = \frac{M_f * C_p * \Delta T_w}{\left(\frac{\Delta T}{\Delta x}\right) * A} \text{ W/M } ^\circ C$$

Where, dt : Change in temperature. ($T_1 - T_4$)

dx : Length Across temperature. = 210 mm = 0.21m

A : Area of the bar ($\pi / 4 * d^2$).

Space For Calculations

RESULT & CONCLUSIONS:

Thermal conductivity of metal rod is found out to be $K = \text{-----} \frac{w}{mk}$

VIVA QUESTIONS:

1. Define thermal conductivity.
2. For which material thermal conductivity is highest?
3. Why negative sign in Fourier's Law?
4. What are the units of thermal conductivity?
5. What is the first law of thermodynamics?
6. What is the second law of thermodynamics?
7. How is thermal conductivity measured practically?
8. Why are diamonds sinks used in cooling electronic components?
9. What is the physical mechanism of conduction in solids, liquids and gases?
10. What do you mean by " ρc_p "?
11. What is the physical significance of thermal diffusivity?
12. Is heat transfer a scalar or vector quantity?
13. What do you mean by steady heat transfer and how does it differ from transient heat transfer?
14. What is lumped system? How does heat transfer in a lumped system differ from steady heat transfer?
15. From heat transfer point of view, what is the difference between isotopic and un isotopic materials?
16. What is heat generation in a solid?
17. How are ordinary and partial differential equations used in heat transfer analysis?
18. What is a boundary condition? Explain.
19. What is the material for which thermal conductivity is to be found in thermal conductivity of solids experiment

EXPERIMENT - 03

HEAT TRANSFER FROM A PIN-FIN APPARATUS

AIM:

1. To draw the variation of temperature along the length of the pin fin under forced convection.
2. To determine the value of heat transfer coefficient under forced convection to find
 - a. Theoretical values of temperature along the length of the fin
 - b. Effectiveness and Efficiency of pi fin

THEORY:

The heat transfer from a heated surface to the ambient is given by the relation $q=hA\Delta T$. In this relation h is the heat transfer coefficient, ΔT is the temperature difference and A is area of heat transfer. To increase q , h may be increased or surface area may be increased. In some cases it is not possible to increase the value of heat transfer coefficient and the temperature difference ΔT and thus the only alternative is to increase the surface area of heat transfer. The surface area is increased by attaching extra material in the form of rod (circular or rectangular) on the surface where we have to increase the transfer rate. "This extra material attached is called the extended surface or fins".

The fins may be attached on a plane surface, then they are called plane surface fins. If the fins are attached on the cylindrical surface, they are called as circumferential fins. The cross section of fin may be circular, rectangular or parabolic.

Temperature distribution and heat transfer from fins from end insulated condition:

Temperature distribution along the length of the fin is

$$\frac{\theta}{\theta_0} = \frac{T-T_\infty}{T_0-T_\infty} = \frac{\cosh m(L-x)}{\cosh mL}$$

Where T = Temperature at any distance X from the fin

T_0 = Temperature at $X=0$

T_∞ = Ambient Temperature

L = Length of the fin

$$m = \sqrt{\frac{hp}{KA}} \quad h_c = \text{Convective heat transfer coefficient}$$

p = perimeter of the fin

A = area of the fin

K = thermal conductivity of the fin

$$\text{Heat flow } q = \theta_0 \tanh mL \sqrt{h * p * k * A}$$

EFFECTIVENESS OF FINS:

Effectiveness of a fin is defined as the ratio of the heat transfer with fin to the heat transfer from the surface without fins.

For end insulated condition:

$$\varepsilon = \sqrt{\frac{PK}{hA}} \operatorname{Tanh} mL$$

The efficiency of fin is defined as the ratio of the actual heat transferred by the fin to the maximum heat transferred by the fin area were at base temperatures.

$$\eta = \frac{\operatorname{tanh} mL}{mL}$$

An aluminium fin of circular cross section is fitted across a long rectangular duct. The other end of the duct is connected to the suction side of a blower and the air flows past the fin perpendicular to the axis. One end of the fin projects outside the duct and is heated by a heater. Temperature at five points along the length of the fin. The air flow rate is measured by an orifice meter fitted on the delivery side of the blower.

Specifications:

1. Diameter of the fin = 15 mm
2. Length of the fin = 170 mm
3. Duct size = 100 mm inner dia
4. Blower = axial flow fan type
5. No: of thermo couples: 3 on the surface of the fin and 2 for air temperature
6. Multichannel Digital Temperature Indicator
7. Voltmeter 0 to 300 volts.
8. Ammeter 0 to 2 Amps.

Thermal conductivity of aluminium, $k=232.56 \frac{W}{mk}$

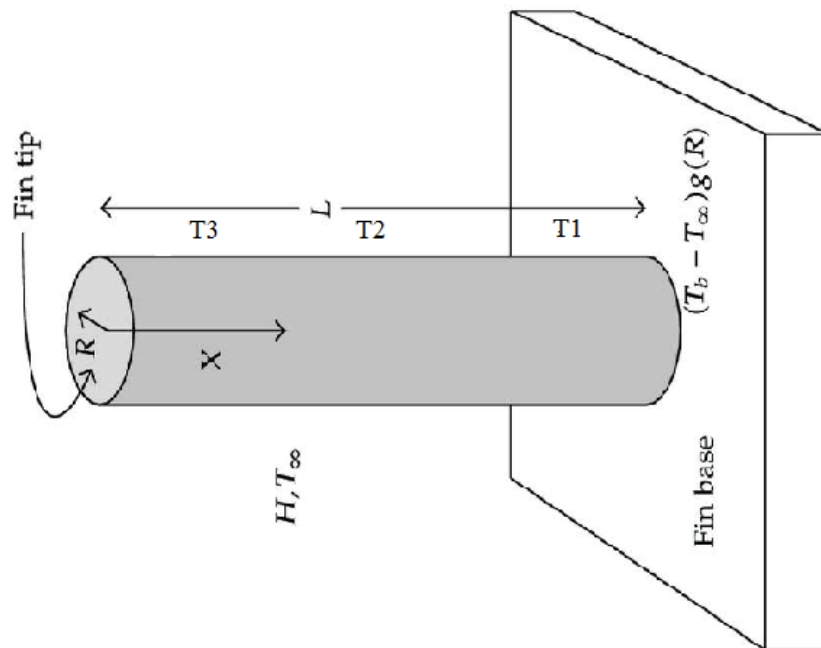

FIG:PIN FIN SETUP

PROCEDURE:

To study the temperature distribution along the length of a pin fin under natural and forced convection, the procedure is as under

Natural Convection:

1. Start heating the fin by switching ON the heater element and adjust the voltage on dimmerstat to say 50 volt
2. Note down the thermocouple reading. T_1 to T_5
3. When steady state is reached, record the final readings 1 to 5 .
4. Repeat the same experiment with voltage 70volts and 90 volts.

Forced Convection:

1. Start heating the fin by switching ON the heater and adjust dimmerstat voltage.
2. Start the blower and adjust the air flow rate to a particular velocity by operating the blower control knob.
3. Note down the thermocouple readings T_1 to T_5
4. When the steady state is reached, record the final reading

Tabular column :

Natural Convection:

Sr. No.	V Volts	I Amps	Q=V*I Watts	Temperatures				
				T ₁ (°C)	T ₂ (°C)	T ₃ (°C)	T ₄ (°C)	T ₅ (°C)
1								
2								
3								
4								

Forced convection:

Sr. No	V Volts	I Amps	Q=V*I Watts	Anemometer reading m/s	Temperatures				
					T ₁ (°C)	T ₂ (°C)	T ₂ (°C)	T ₄ (°C)	T ₅ (°C)
1									
2									
3									
4									

Calculations:

1. V_a = Velocity of air in the duct = 4.2 m/sec from Aneometer

.Average Surface Temperature of Fin is given by,

$$T_s = \text{Surface temperature} = \frac{T_2 + T_3 + T_4}{3}$$

$$T_\infty = \text{Ambient temperature} = \frac{T_1 + T_5}{2}$$

$$T_M = \text{Mean temperature} = \frac{T_s + T_\infty}{2}$$

From Dry air atmospheric pressure table take the following values from data book

$V = \text{-----m}^2/\text{sec}$, $P_r = \text{-----}$, $K = \text{-----W/m k}$, $d_f = 0.015 \text{ m}$

$$RE = \text{Reynolds number} = \frac{V_a * d_f}{\gamma}$$

The relation for Nu is

2) $Nu = C * Re^n * P_r^{1/3}$

The value of C, and n from standard table

$Re = 0.4 \text{ to } 4.0$	$C = 0.989, n = 0.33$
$Re = 4 \text{ to } 40$	$C = 0.911, n = 0.385$
$Re = 40 \text{ to } 4000$	$C = 0.683, n = 0.466$
$Re = 4000 \text{ to } 40000$	$C = 0.293, n = 0.618$
$Re = 40000 \text{ to } 400000$	$C = 0.27, n = 0.805$

$$h_c = \frac{Nu * K}{d_f}$$

Where K Thermal conductivity of air at Mean temperature = ----- W/m²k

3) $m = \sqrt{\frac{hp}{KA}}$ where P= perimeter= πd_f
 A= Area= $\pi/4 * d_f^2$

K=Thermal conductivity of Aluminium material= $232.56 \frac{W}{mk}$

4) Temperature distribution is given by

$$\frac{T - T_\infty}{T_0 - T_\infty} = \frac{\cosh m(L-x)}{\cosh mL}$$

$$T = T_\infty + (T_0 - T_\infty) \frac{\cosh m(L-x)}{\cosh mL}$$

Where X is the thermocouple distance at different positions.

$X = X_1, X_2, X_3,$

Where T=Temperatures at above points
T=T₁, T₂, T₃,

Given thermocouple distance X₁=30 mm= 0.03 m
X₂= 50 mm= 0.05 m
X₃= 80 mm= 0.08 m

$$T = T_{\infty} + (T_0 - T_{\infty}) \frac{\cosh m(L-x)}{\cosh mL}$$

T=T₁ at X=X₁, T=T₂ at X=X₂, T=T₃ at X=X₃

Distance X in mts	Temperature from experiment in deg. c	Temperature from calculation in deg. c

$$\text{Effectiveness of pin fin} = \varepsilon = \sqrt{\frac{PK}{hA}} \tanh mL$$

$$\text{Efficiency of pin fin} = \eta = \frac{\tanh mL}{mL}$$

Plot a graph of temperature distribution along the length of the pin fin from observed readings. Also draw the graph of calculated temperature readings along the length of the fin

Precautions:

1. See that the dimmerstat is at zero position before switching ON the heater.
2. Operate the changeover switch of temperature indicator, gently.
3. Be sure that the steady state is reached before taking the final reading.

Space For Calculations

RESULT & CONCLUSIONS:

Heat transfer coefficient for the fin for natural convection is = $W/m^2 K$

Heat transfer coefficient for the fin for forced convection is = $W/m^2 K$

Effectiveness of the pin fin is = $\epsilon =$

Efficiency of the pin fin is = $\eta =$

VIVA QUESTIONS:

1. What is convection?
2. Classify convection.
3. What is forced convection & natural convection?
4. Explain difference between forced convection and natural convection?
5. Force convection in a liquid bath is caused by----
6. Explain Newton's law of cooling?
7. Give the relation between 'Fluid velocity' and 'Heat transfer'?
8. On which properties does convection heat transfer strongly depend?
9. Define convection heat transfer coefficient with dimensions.
10. Define Nussult number.
11. Develop velocity boundary layer for flow over a flat plate?
12. Explain Prandtl number.
13. Fluid properties are evaluated at what temperature?
14. The Prandtl number will be lowest for-----
15. What is significance of Nussult's number in convection?
16. The hydro dynamic and thermal boundary layers are identical at Prandtl number equal to-
17. The temperature gradient in the fluid flow over a heated plate will be-----
18. The ratio of heat transfer by convection to that by conduction is called-----
19. Define buoyancy force and discuss significance of the buoyancy force in Natural convection?
20. Define volume expansion coefficient and discuss significance in Natural convection?
21. Define Grashoff number and discuss significance of Grashoff number?
22. What is significance of Rayleigh's number?
23. The free convection heat transfer is significantly affected by----
24. What is significance of Stanton number?
25. The convective heat transfer coefficient from a hot cylindrical surface exposed to still air varies in accordance with-----
26. For Laminar conditions, the thickness of thermal boundary layer increases with the distance from the leading edge in proportion to-----
27. What is the material used in pin fin experiment?

EXPERIMENT - 04

EMISSIVITY MEASUREMENT APPARATUS

AIM:

To determine Emissivity of radiating test plate surface.

THEORY:

All substances at all temperatures emit thermal radiation. Thermal radiation is an electromagnetic wave and does not require any material medium for propagation. All bodies can emit radiation and have also the capacity to absorb all or a part of the radiation coming from the surrounding towards it. An idealized black surface is one, which absorbs all the incident radiation with reflectivity and transmissivity equal to zero. The radiant energy per unit time per unit area from the surface of the body is called, as the emissivity of the surface is the ratio of the emissive power of the surface to the emissive power of a black surface at the same temperature. It is noted by E. For black body absorptivity = 1 and by the knowledge of Kirchoff's Law emissivity of the black body becomes unity. Emissivity being a property of the surface depends on the nature of the surface and temperature. It is obvious from the Stefan Boltzmann's Law that the prediction of emissive power of a surface requires knowledge about the values of its emissivity and therefore much experimental research in radiation has been concentrated on measuring the values of emissivity as function of surface temperature. The present experimental set up is designed and fabricated to measure the property of emissivity of the test plate surface at various temperatures

Under steady state conditions:

W_1 = Heater input black plate.

Watts = $V_1 \cdot I_1$

W_2 = Heater input to test plate.

Watts = $V_2 \cdot I_2$

Area of plates = $A = \frac{\pi}{4} D^2$

d = Diam. Of plate = 2000mm

T_1 = Temperature of black body $^{\circ}K$

T_3 = Inside temperature of enclosure $^{\circ}K$

T_2 = Temperature of grey body $^{\circ}K$

E_b = Emissivity of black plate.

(To be assumed equal to unity.)

E = Emissivity of test plate

σ = Stefan Boltzmann constant

$$5.67 \times 10^{-8} \frac{W}{M^2 K^4}$$

By using the Stefan Boltzmann Law:

$$W_1 - W_2 = \frac{(E_b - E) * \sigma * A * (T_1^4 - T_2^4)}{0.86}$$

Specifications:

1. Test plate made of circular aluminium plate with polished surface, mounted on asbestos cement sheet, diameter: 200mm
2. Black body made of circular aluminium plate with surface black Teflon coated, mounted on asbestos cement sheet, diameter: 200mm
3. Heaters for Nichrome strip wound on mica sheet and sandwiched between two mica sheets capacity of heater = 200 watts each approx.
4. Digital voltmeter and ammeter.
5. Enclosure size 580mm x 300mm x 300mm approximately with one side Perspex and bottom fitted on cement sheet.
6. Thermocouples – Chromel Alumel – (3Nos).
7. Channel selector and digital temper display.
8. Regulator to vary input power to heaters independently.

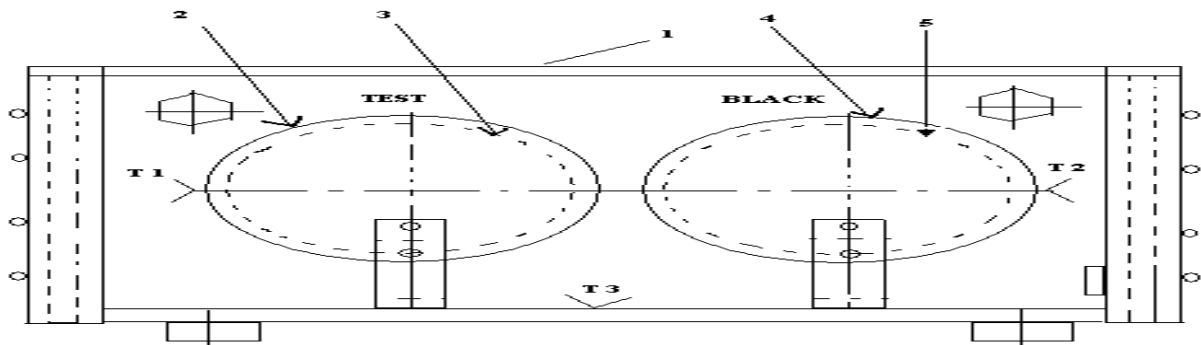

FIG: EMISSIVITY MEASUREMENT APPARATUS

- (1) Enclosure (2) Test Plate (3) Test Plate Heater (4) Black body
(5) Black body Heater T 1 to T 3 Thermocouple Position

PROCEDURE:

1. Gradually increase the input to the heater to black plate and adjust it to some value viz. 30, 50, 75 watts and adjust the heater input to test plate slightly less than the black plate 27, 35, 55 watts etc.
2. Check the temperature of the two plates with small time intervals and adjust the input of test plate only, by the dimmerstat so that the two plates will be maintained at the same temperature.
3. This will required some trial and error and one has to wait sufficiently (more than one hour or so) to obtain the steady state condition.
4. After attaining the steady state condition record the temperatures. Voltmeter and Ammeter readings for both the plates.
5. The same procedure is repeated for various surface temperatures in increasing order.

Tabular column:

Sr. No.	BLACK BODY				TEST PLATE				ENCLOSURE TEMP.	Emissivity E
	V ₁	I ₁	W ₁ =V ₁ *I ₁ Watts	T ₁	V ₂	I ₂	W ₂ =V ₂ *I ₂ Watts	T ₂	T ₃ °C	
1										
2										
3										
4										

Calculations:

$$W_1 - W_2 = \frac{(E_b - E) * \sigma * A * (T_1^4 - T_2^4)}{0.86}$$

$$\sigma = 5.67 \times 10^{-8} \frac{W}{M^2K^4}$$

E = Emissivity of Test plate to be determined

This fact could be verified by performing the experiments at various values of T_2 and E can be plotted in a graph

$$E = 1 - \left\{ \frac{0.86 * (W_1 - W_2)}{\sigma * A * (T_1^4 - T_2^4)} \right\}$$

Space For Calculations

RESULT & CONCLUSIONS:

Emissivity of radiating test plate surface is found out to be $E = \text{-----}$

VIVA QUESTIONS:

1. Explain Radiation.
2. Heat energy transfers in radiation in which form?
3. What is a Black body?
4. Explain Stefan – Boltzman’s law? What is value of the Stefan – Boltzman constant?
5. Explain spectral blackbody emissive power?
6. Discuss Planck’s distribution law.
7. Define emissivity.
8. Explain absorptivity, reflectivity and transmissivity.
9. Define irradiation.
10. Explain Kirchoff’s law.
11. Radiation between two surfaces mainly depends on-----
12. Define Shape factor (or) view factor (or) configuration factor (or) angle factor
13. Explain Radiosity?
14. Explain Radiation Heat transfer between two surfaces?
15. What is network representation and what is its algebra?
16. Define Radiation shields?
17. Thermal radiation occurs in the portion of electromagnetic spectrum between the wavelengths -----
18. For infinite parallel plates with emissivities ϵ_1 and ϵ_2 shape factor for radiation from surface 1 to surface 2 is -----

EXPERIMENT - 05

STEFAN BOLTZMANN APPARATUS

AIM:

To determine the Stefan- Boltzmann's constant in the radiation heat transfer.

THEORY:

All the substances emit thermal radiation. When heat radiation is incident over a body, part of radiation is absorbed, transmitted through and reflected by the body. A surface which absorbs all thermal radiation incidents over it is called black surface. For black surface, transmissivity and reflectivity are zero and absorptivity is unity. Stefan Boltzmann Law states that emissivity of a surface is proportional to fourth power of absolute surface temperature i.e.

$$E \propto T^4$$

$$\text{Then heat transfer rate } Q = \sigma * A * (T_H^4 - T_C^4)$$

Where

E = emissive power of surface, W / m² T = absolute temperature

σ = Stefan Boltzmann constant

$$\sigma = 5.667 \times 10^{-8} \text{ W / m}^2 \text{ K}^4$$

T_H = Temperature of hot body

T_C = Temperature of cold body

The Apparatus consists of a water-heated jacket of hemispherical shape. A copper test disc is fitted at the center of jacket. The hot water is obtained from a hot water tank, fitted to the panel, in which water is heated by an electric immersion heater. The hot water is taken around the hemisphere, so that hemisphere temperature rises. The test disc is then inserted at the center. Thermocouples are fitted inside hemisphere to average out hemisphere temperature. Another thermocouple fitted at the center of test disc measures the temperature of test disc. A timer with a small buzzer is provided to note down the disc temperatures at the time intervals of 25 seconds.

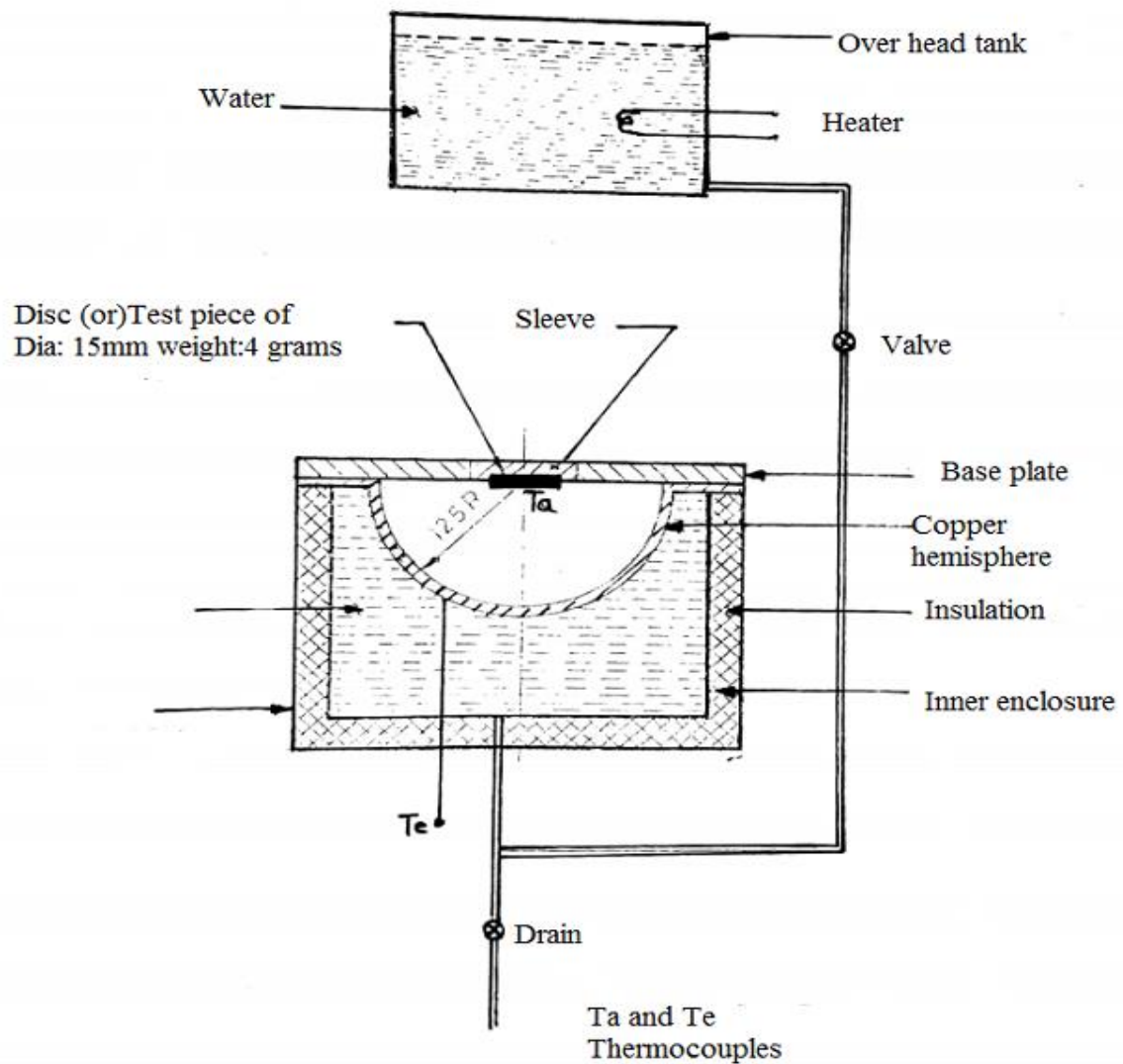

FIG:STEFAN BOLTZMANN'S CONSTANT APPARATUS

PROCEDURE:

1. Switch on the mains and the console
2. Put 'ON' the heater.
3. Remove the disc (D) or test piece
4. After water attains the maximum temperature open the valve and dump the water to the enclosure jacket
5. Note down the hemisphere temperatures
6. Note down the test disc temperature
7. Start the timer. At the start of timer cycle, insert test disc into the hole of hemisphere.
8. Note down the temperatures of disc for every 25 seconds

Tabular column:

T_1 =Enclosure Temperature ($^{\circ}$ C)=

T_2 =Temperature of disc ($^{\circ}$ C)=

Time In Seconds	Temperature Of Disc $^{\circ}$ C
0	
25	
50	
75	
100	
125	
150	
175	
200	
225	
250	
275	
300	

Calculations

1) Area of test disc, $A = (\pi/4)*d^2 =$ $d=15$ mm

2) mass of test disc, $m = 4$ grams =0 .004 kg.

3) Initial Test disc temperature(T_D)

$T_D =$

As area of hemisphere is very large as compared to that disc, we can put

$Q = \sigma * A * (T_1^4 - T_2^4)$ -----(1)

Where Q = heat gained by disc/sec.

$$Q = m * C_p * \frac{dT}{dt} \text{-----(2)}$$

Equating equation 1 and 2

$$\sigma * A * (T_1^4 - T_2^4) = m * C_p * \frac{dT}{dt}$$

$$4)\sigma = \frac{m * C_p * \frac{dT}{dt}}{A * (T_1^4 - T_2^4)} \quad \frac{W}{M^2 K^4}$$

dT = Change in temperature of the disc

dt = Change in time = 300sec

C_p = Specific heat of copper disc = 410 J/Kg °C

Theoretical value of $\sigma = 5.667 \times 10^{-8} \frac{W}{M^2 K^4}$

In the experiment this value may deviate due to reasons like convection, temperature drop of hemisphere, heat losses etc.

Precautions:

1. Never put 'ON' the heater before putting water in the tank.
2. Put 'OFF' the heater before draining the water from heater tank.
3. Drain the water after completion of experiment.
4. Operate all the switches and controls gently

Plot the graph for temperature of the absorber Vs time

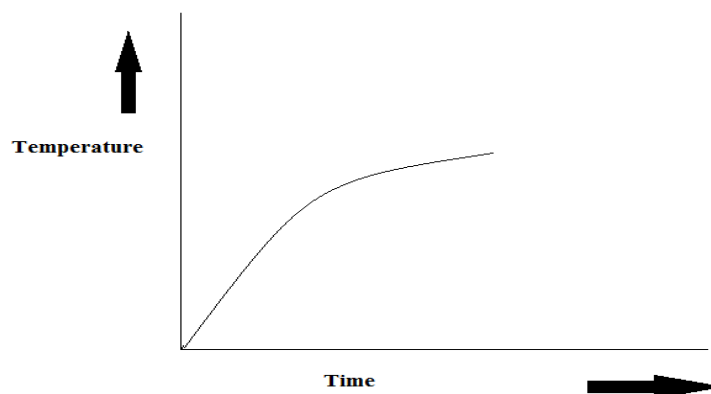

GRAPH : TEMPERATURE Vs TIME

Space For Calculations

RESULT & CONCLUSIONS:

Stefan – Boltzmann’s constant, $\sigma =$ _____ $\frac{W}{M^2K^4}$

VIVA QUESTIONS:

1. Explain Radiation.
2. Heat energy transfers in radiation in which form?
3. What is a Black body?
4. Explain Stefan-Boltzmann's law? What is value of the Stefan- Boltzmann constant?
5. Explain spectral blackbody emissive power?
6. Discuss Planck's distribution law.
7. Define emissivity.
8. Explain absorptivity, reflectivity and transmissivity.
9. Define irradiation.
10. Explain Kirchhoff's law.
11. Radiation between two surfaces mainly depends on-----
12. Define Shape factor (or) view factor (or) configure factor (or) angle factor
13. Explain Radiosity?
14. Explain Radiation Heat transfer between two surfaces?
15. What is network representation and what is its algebra?
16. Define Radiation shields?
17. Thermal radiation occur in the portion of electro magnetic spectrum between the wavelengths -----
18. For infinite parallel plates with emissivity's ϵ_1 and ϵ_2 shape factor for radiation from surface 1 to surface 2 is -----

EXPERIMENT - 06

PARALLEL FLOW / COUNTER FLOW HEAT EXCHANGER

AIM:

To determine heat transfer rate and overall heat transfer coefficient of Parallel flow and counter flow heat exchanger.

To determine NTU, Effectiveness and Efficiency of Parallel flow and counter flow heat exchanger.

THEORY:

Heat exchanger is a device used for affecting the process of heat exchange between two fluids that are at different temperatures. It is useful in many engineering processes like those in Refrigeration and Air conditioning system, power system, food processing systems, chemical reactor and space or aeronautical applications. The necessity for doing this arises in multitude of industrial applications. Common examples of best exchangers are the radiator of a car, the condenser at the back of the domestic refrigerator, and the steam boiler of a thermal power plant.

The simple example of transfer type of heat exchanger can be in the form of a tube in tube type arrangement . Hot fluid flowing through the inner tube and the Cold through the annulus surroundings it. The heat transfer takes place across the walls of the inner tube. The experiments are conducted by keeping the identical flow rates [approx] while running the unit as a parallel flow heat exchanger and counter flow exchanger.

The temperatures are measured with the help of the temperature sensor. The readings are recorded when steady state is reached. The outer tube is provided with adequate insulation to minimize the heat losses.

The PF & CF heat exchanger consist of following components

1. Main Frame
2. Heat Exchanger
3. Temperature Indicator
4. Hot water Generator
5. Rota meter for hot & cold water flow rate measurement
6. Temperature Sensors

The total assembly is supported on a main frame. The apparatus consists of a 'tube in tube' type concentric tube heat exchanger. The hot fluid is water, which is obtained from the hot water generator it is attached at the top of assembly to supply the hot fluid. Different valves are provided in the system to regulate the flow of fluid to the system. The hot water & cold water admitted at the same end & the opposite end, named parallel & counter flow heat exchanger accordingly, is done by valve operation.

The concentric type heat exchanger is connected in system, which transfers thermal energy between two fluids at different temperature.

Specification:

Inner Tube Material	: copper
Outer Diameter (do)	: 19 mm
Thickness	: 1.2mm
Outer Tube Material	: Stainless steel
Inner Diameter (Di)	: 50 mm
Length of the heat Exchanger (L)	: 1000 mm
Heater	: 1kw x 01 No.
Thermostat	: 1 (Range10-110 ⁰ C)
Temperature Indicator	: 6 Channel (0 to 200 ⁰ C), 0.1 ⁰ C Resolution
MCB	: 16 Amp for Heater,

Type of Heat Exchangers:

Heat exchangers are classified in three categories.

1. Transfer Type

According to flow arrangement

2. Parallel flow
3. Counter flow

Storage Type

1. Direct Transfer Type
2. Shell and tube heat Exchanger

A Transfer type heat exchanger is the one in which both fluids pass simultaneously flow through the device and heat is transferred through separating walls. In practice most of the heat exchangers used are transfer type ones. The transfer type heat exchangers are further classified according to flow arrangements as

Parallel Flow, in which fluids flow in the same direction.

Counter flow, in which they flow in opposite direction.

PROCEDURE:

1. Operate the valve system to make water flow either in parallel or counter flow direction.
2. Allow the water to circulate in the inner copper tube by opening flow control valve of the rotameter, to monitor the flow rate.
3. Switch on the water heater to heat the water.
4. Once the temperature of hot water is reached steady state start the flow of water through hot and cold water side and adjust it as per requirement.
5. For Parallel flow the flow of hot & cold water should be on same side & for counter flow the flow of both the fluids should be on opposite side. Make this adjustment with the help of valves
6. Wait to stabilized the temperature on the indicator.
7. As the temperature get stabilized take down the readings for different four channels by using switch on the panel.
8. Readings for the flow rates can be taken from the rotameter attached at the front of the instrument.
9. Take down the readings by varying the flow rates.
10. Observe flow rate of hot water to be less than flow rate of cold water
11. Once the experiment is completed drain the water remains in concentric tube. By opening the cocks given at side & below the shell.

Observation:

Inner Tube

Inner tube material = Copper (COLD WATER FLOWS)

Diameter (do) = 19 mm = 0.019 m

Thickness = 1.2mm

Outer Tube

Outer tube Material = STAINLESS STEEL. (HOT WATER FLOWS)

Diameter (D) = 50 mm = 0.055 m

Length of the heat Exchanger = 1000 mm = 1.0 m

Constants:

1. C_{pc} = Specific heat of cold water = 4.174 KJ / KG k
2. C_{ph} = Specific heat of hot water = 4.174 KJ / KG k

Tabular column – I:

Parallel Flow Run:

S. NO.	HOT WATER SIDE			COLD WATER SIDE		
	Flow rate m_h (Kg/hr)	Inlet Temp. T_{hi} (°C)	Outlet Temp. T_{ho} (°C)	Flow rate m_c (Kg/hr)	Inlet Temp. T_{ci} (°C)	Outlet Temp. T_{co} (°C)
1						
2						
3						
4						

Note: T_{ci} in parallel is becoming T_{co} in counter Flow while making necessary Correction.

Calculation for Parallel Flow:

- 1) Q_h = Heat transfer rate from hot water in KJ / sec

$$Q_h = M_h * C_{ph} * (T_{hi} - T_{ho})$$

- 2) Q_c = Heat transfer rate from cold water in KJ /sec

$$Q_c = M_c * C_{pc} * (T_{co} - T_{ci})$$

Q = Total heat transfer rate in KJ /sec

$$3) Q = \frac{Q_h + Q_c}{2}$$

- 4) ΔT_{lm} = Logarithmic mean temperature difference in °K

$$\Delta T_{lm} = \frac{T_{in} - T_{out}}{\ln \frac{T_{in}}{T_{out}}}$$

Where

$$T_{in} = T_{hi} - T_{ci}$$

$$T_{\text{out}} = T_{\text{ho}} - T_{\text{co}}$$

5) U_o = Overall heat transfer coefficient based on outer area in $W / m^2 K$

$$U_o = \frac{Q_c}{A_o * \Delta T_m}$$

A_o = Area of outer side tube in m^2

$$A_o = \pi * d_o * L$$

d_o = diameter of outer tube = 0.055m

6) U_i = Overall heat transfer coefficient based on inner area in $W / m^2 K$

$$U_i = \frac{Q_h}{A_i * \Delta T_m}$$

A_i = Area of inner side tube in m^2

$$A_i = \pi * d_i * L$$

d_i = diameter of inner tube = 0.019m , $L=1m$

7) C = Capacity ratio

$$C = \frac{C_{\text{min}}}{C_{\text{max}}}$$

Where,

$$C_{\text{min}} = M_h * C_{\text{ph}}$$

$$C_{\text{max}} = M_c * C_{\text{pc}}$$

8) ϵ = Effectiveness of heat exchanger

$$\epsilon = \frac{M_c * C_{\text{pc}} * (T_{\text{co}} - T_{\text{ci}})}{M_{\text{cp}_{\text{min}}} * (T_{\text{hi}} - T_{\text{ci}})} = \epsilon = \frac{M_h * C_{\text{ph}} * (T_{\text{hi}} - T_{\text{ho}})}{M_{\text{cp}_{\text{min}}} * (T_{\text{hi}} - T_{\text{ci}})}$$

$$M_{cp_{\min}} = M_h * C_{ph} < M_c * C_{pc} \quad \varepsilon = \frac{T_{hi} - T_{ho}}{T_{hi} - T_{ci}}$$

$$M_{cp_{\min}} = M_c * C_{pc} < M_h * C_{ph} \quad \varepsilon = \frac{T_{co} - T_{ci}}{T_{hi} - T_{ci}}$$

9) NTU_i = No. of transfer unit for inner surface

$$NTU_i = \frac{U_i * A_i}{C_{\min}}$$

10) NTU_o = No. of transfer unit for outer surface

$$NTU_o = \frac{U_o * A_o}{C_{\min}}$$

Tabular column – II:

Counter Flow Run :

SR. NO.	Hot Water Side			Cold Water Side		
	Flow rate m_h (Kg/hr)	Inlet Temp. T_{hi} (°C)	Outlet Temp. T_{ho} (°C)	Flow rate m_c (Kg/hr)	Inlet Temp. T_{ci} (°C)	Outlet Temp. T_{co} (°C)
1						
2						
3						
4						

Note: T_{ci} in parallel is becoming T_{co} in counter Flow while making necessary Correction.

Calculation For Counter Flow:

1) Q_h = Heat transfer rate from hot water in KJ / sec

$$Q_h = M_h * C_{ph} * (T_{hi} - T_{ho})$$

2) Q_c = Heat transfer rate from cold water in KJ /sec

$$Q_c = M_c * C_{pc} * (T_{co} - T_{ci})$$

3)Q = Total heat transfer rate in KJ /sec

$$Q = \frac{Q_h + Q_c}{2}$$

4) Δ_{Tm} = Logarithmic mean temperature difference in $^{\circ}K$

$$\Delta_{Tm} = \frac{T_{in} - T_{out}}{\ln \frac{T_{in}}{T_{out}}}$$

Where,

$$T_{in} = T_{hi} - T_{co}$$

$$T_{out} = T_{ho} - T_{ci}$$

5) U_o = Overall heat transfer coefficient based on outer area in $W / m^2 K$

$$U_o = \frac{Q_c}{A_o * \Delta_{Tm}}$$

A_o = Area of outer side tube in m^2

$$A_o = \pi * d_o * L \quad d_o = \text{diameter of outer tube} = 0.055m, L = 1m$$

6) U_i = Overall heat transfer coefficient based on inner area in $W / m^2 K$

$$U_i = \frac{Q_h}{A_i * \Delta_{Tm}}$$

A_i = Area of inner side tube in m^2

$$A_i = \pi * d_i * L \quad d_i = \text{diameter of inner tube} = 0.019m, L = 1m$$

7) ϵ = Effectiveness of heat exchanger

$$\varepsilon = \frac{M_c * M_{pc} * (T_{co} - T_{ci})}{M_h * M_{ph} * (T_{hi} - T_{ci})} \quad \text{With } M_h < M_c$$

8) C = Capacity ratio

$$C = \frac{C_{\min}}{C_{\max}}$$

Where,

$$C_{\min} = M_h * C_{ph}$$

$$C_{\max} = M_c * C_{pc}$$

9) NTU_i = No. of transfer unit for inner surface

$$NTU_i = \frac{U_i * A_i}{C_{\min}}$$

10) NTU_o = No. of transfer unit for outer surface

$$NTU_o = \frac{U_o * A_o}{C_{\min}}$$

Precautions

1. Do not put on heater unless water flow is continuous.
2. Once the flow is fixed, do not change it until note down the readings for that flow.
3. The thermocouples should keep in pockets
4. There should make the oil well in pockets of thermocouple.
5. Equipment should be earthed prop
6. Once the experiment is completed drain out the water remain in both the tubes.

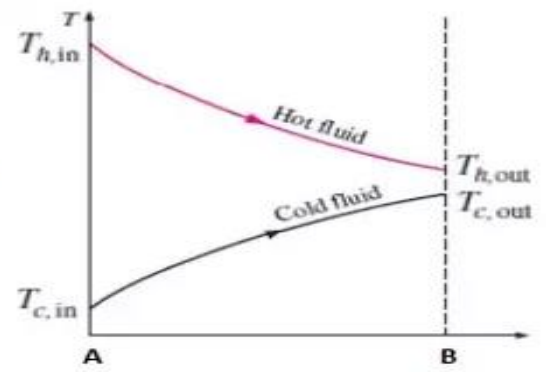
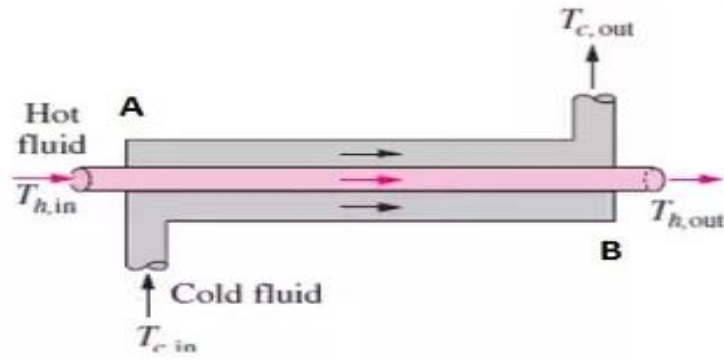

PARALLEL FLOW

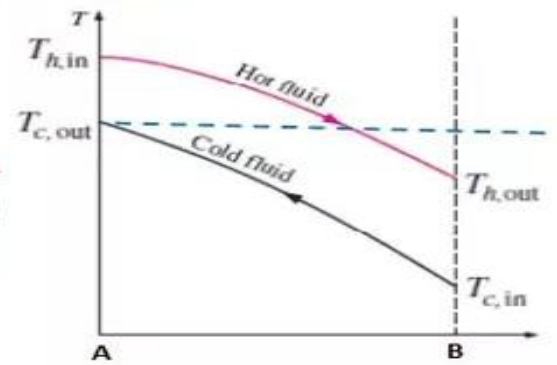
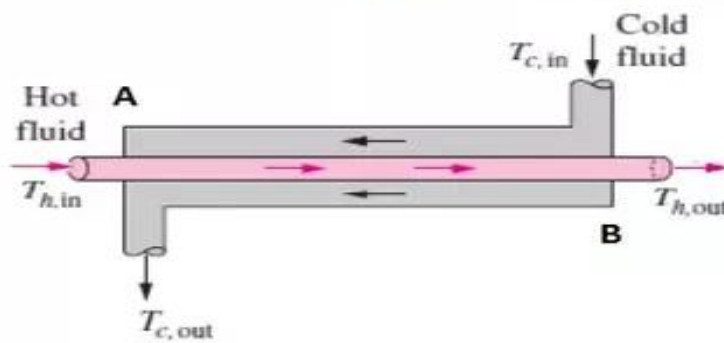

COUNTER FLOW

FIG: PARALLELFLOW AND COUNTERFLOW SET UP

Space For Calculations

RESULT & CONCLUSIONS:

TYPE OF FLOW	Over All Heat Transfer (U)		Effectiveness ϵ	Capacity Ratio C	NTU	
	U_o	U_i			NTU_i	NTU_o
Parallel flow						
Counter flow						

VIVA QUESTIONS:

1. Explain about a heat exchanger.
2. Classify heat exchangers.
3. Which type of heat transfer takes place in heat exchangers?
4. What is fouling?
5. Classify fouling?
6. What is the relation between fouling and overall heat transfer coefficient?
7. Define heat capacity ratio?
8. Explain different methods to design heat exchangers?
9. Define LMTD
10. Explain LMTD for parallel flow
11. Explain LMTD counter flow
12. What is correction factor?
13. What is effectiveness?
14. Explain effectiveness in parallel and counter flow?
15. Expand NTU
16. The normal automobile radiator is a heat exchanger of which type?
17. The Condenser in a thermal power plant is an exchanger of which type?
18. The effectiveness of heat exchanger is given by-----

EXPERIMENT - 07

PERFORMANCE TEST ON VAPOR COMPRESSION REFRIGERATION TEST RIG

AIM:

To find the COP of the refrigeration System

THEORY:

The ideal thermodynamic cycle on which the refrigerator works is the vapor compression cycle shown in the following figure, on both T – s and p – h coordinates

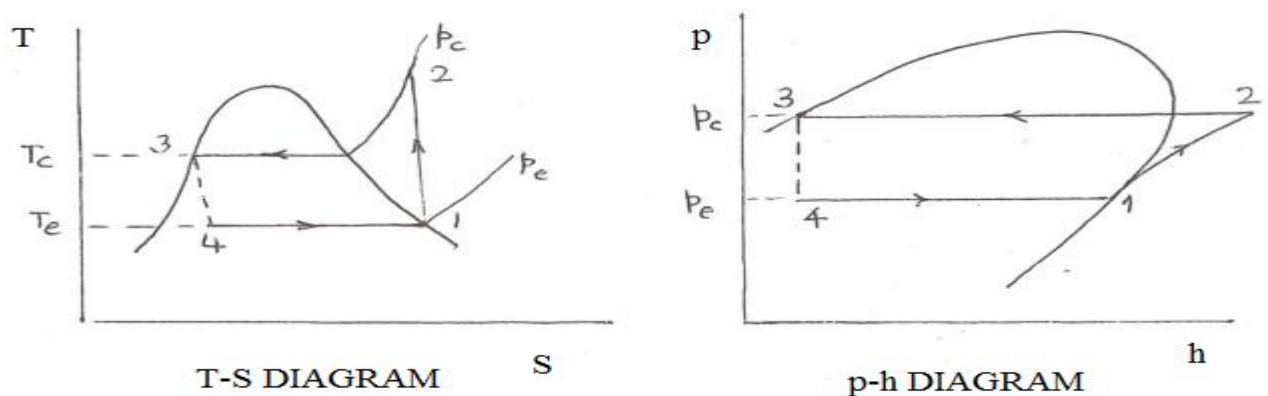

FIG: VAPOUR COMPRESSION CYCLE

The cycle consists of four processes:

Process 1-2 :

The refrigerant vapor leaving the evaporator is compressed isentropically from state 1 to 2 . In the ideal cycle state 1 corresponds to the saturated vapor state for the evaporator temperature . At state 2 the pressure is equal to the condenser pressure and entropy = entropy at state 1. Work of compression ,per kg refrigerant, W_c is given by:

$$W_c = (H_2 - H_1)$$

Process 2-3:

During the constant pressure process 2-3 the compressed vapor at state 2 is cooled to the saturation temperature t_c , also called the condensing temperature , and then condensed to saturated liquid at state 3 The magnitude of rejected heat by the condenser Q_c is given by:
 $Q_c = (H_2 - H_3)$

Process 3 – 4 :

The high pressure liquid at state 3, at the condenser pressure, is throttled during 3-4 to evaporator pressure at 4 by passing it through either an expansion valve or a capillary. During throttling process there is no change in enthalpy.

Process 4 – 1 :

This is the process during which cooling is realized. Liquid entering the evaporator at state 4, picks up heat from the refrigerator at the evaporator temperature (t_e) and leaves the evaporator at state 1 as saturated vapor. The cooling produced per kg refrigerant, Q_1 is given by: $Q_1 = (H_1 - H_4)$

The COP of the refrigerator is given by:

$$\text{COP} = \frac{Q_1}{W_C} = \frac{H_1 - H_4}{H_2 - H_1}$$

The experimental set up is an actual vapor compression refrigeration system with provisions to measure pressures and temperature at various locations. Both options, capillary tube and an expansion valve, are available in the system to expand the refrigerant between the condenser and the evaporator, The COP can be computed, with the help of the experimental observations the refrigerant used in the system is

R 134 a.

PROCEDURE:

1. Switch “on” the Mains and the console
2. Select the type of expansion by operating the switch to respective position.
i.e capillary open/Expansion valve open
3. Switch “on” the compressor and the fan
4. Now cooling takes place at the selected expansion device
5. Wait for 30 minutes
6. Record the following readings:
 - a. Pressures P_1 and P_2 as indicated on the compound and pressure gauges respectively.
 - b. Temperatures at locations $T_1, T_2, T_3, T_4, T_5, .$
 T_1 =Temperature at compressor inlet
 T_2 = Temperature at compressor out let
 T_3 = Temperature at Condenser outlet
 T_4 = Temperature after throttling
 T_5 = Temperature inside Freezer
 P_1 =Suction Pressure of compressor ,PSI
 P_2 = Discharge Pressure of compressor ,PSI
7. The experimental is to be conducted on both the expansion devices which are capillary & thermo static expansion valve individually

Tabular column:

Expansion devices	Power input to compressor	T ₁	T ₂	T ₃	T ₄	T ₅	P ₁ PSI	P ₂ PSI
Capillary open								
Expansion valve open								

Calculations:

In VCR cycle the steady state heat balance is given by

$$Q_1 + W = Q_2 \text{(1)}$$

Where Q₁ = Heat removed by the evaporator from the refrigerated system

Heat gained by the refrigerant in the evaporator

1) $Q_1 = H_1 - H_4$ Per kg of refrigerant

Q₂ = Heat transferred from the refrigerant in the condenser

2) $Q_2 = H_2 - H_3$ Per kg of refrigerant

W = Work done by the compressor on the refrigerant

3) $W = H_2 - H_1$ Per kg of refrigerant

H₁ = Enthalpy of refrigerant at exit of the evaporator

H₂ = Enthalpy of refrigerant at exit of the compressor

H₃ = Enthalpy of refrigerant at exit of the condenser

H₄ = Enthalpy of refrigerant at exit of the throttle valve

The values of enthalpies of the refrigerant at different states can be obtained from tables/charts using the measured values of pressure and temperatures. The work done by the compressor can be directly obtained from the panel. The coefficient of performance (COP) of refrigerant system is given by

$$4) \text{COP} = \frac{Q_1}{W_c} = \frac{H_1 - H_4}{H_2 - H_1}$$

$$\text{Ton of refrigeration} = \frac{\text{HP}}{\text{COP}}$$

Space For Calculations

RESULT & CONCLUSIONS:

Expansion device	Experimental COP	Ton of refrigeration	Relative COP
Capillary valve			
Expansion valve			

VIVA QUESTIONS:

1. Define Refrigeration.
2. Differentiate between Heat Engine and Heat Pump.
3. Define C.O.P
4. Differentiate between source and sink
5. What is a unit of Refrigerant.
6. Explain the working principal of Refrigerant ?
7. What is the use of Expansion Valve ?
8. Explain the working principal of Capillary Tube ?
9. Explain the working principal of Refrigeration Cycle ?
10. Give Example of Refrigerant Used ?

EXPERIMENT - 08

AXIAL FLOW FAN TEST RIG.

AIM:

The experiment is conducted at various pressures to
Determine the Overall efficiency.
Determine the Isothermal efficiency.

THEORY:

Axial compressors are rotating, airfoil based compressors in which the working fluid principally flows parallel to the axis of rotation. This is in contrast with other rotating compressors such as centrifugal, axi-centrifugal and mixed-flow compressors where the air may enter axially but will have a significant radial component on exit. Axial flow compressors produce a continuous flow of compressed gas, and have the benefits of high efficiencies and large mass flow capacity, particularly in relation to their cross-section. They do, however, require several rows of airfoils to achieve large pressure rises making them complex and expensive relative to other designs (e.g. centrifugal compressor). Axial compressors are widely used in gas turbines, such as jet engines, high speed ship engines, and small scale power stations. They are also used in industrial applications such as large volume air separation plants, blast furnace air, fluid catalytic cracking air, and propane dehydrogenation. Axial compressors, known as superchargers, have also been used to boost the power of automotive reciprocating engines by compressing the intake air, though these are very rare. However, elsewhere the total design and capacities have been discussed in standard textbooks, here, the equipment is designed according to the standards and to the very minimum capacity as because these are designed in large stages and capacities which may vary in the range of several horsepower to 'n' number of stages. In this equipment an attempt has been made to design the equipment for the purpose of the academic purpose hence, certain main streams have been neglected due to complexities in manufacturing the educational versions of smaller units, however, the key features have been maintained to the maximum extent

The apparatus consists of Single Stage Compressor according to the standard design. The compressor is directly coupled to a A.C motor of 5hp capacity by means of Flange coupling. The motor is controlled by means of AC Drive of same capacity to conduct the experiment at different speeds. Pressure Tapings are provided at inlet, stages and outlet, with manometer for measuring. Multi Tube Manometers are made of clear Acrylic with vinyl sticker scale to for better readings. Starter for the motor and Energy meter for power measurement are provided in the control panel with other necessary instruments. Compressor assembly with motor is mounted on the separate frame made of C – channel. This makes the complete assembly sturdy.

Specifications:

Axial Fan : a) Aero foil type with provisions to change the blade angle. Mounted on shaft and housed in circular duct 400mm dia

b) Speed: 0-2900RPM

Motor : 5HP A.C Motor, 3ph, 440v, 15A

Drive: VFD drive for AC motor speed control (0-2900)

Electrical input: 3ph, 415V, 20A, AC supply with neutral and earth

Measurements:

Speed: By digital meter

Static head rise: Measured at up stream of impeller on surface of duct connected to u-tube manometer in terms of height of water column

Flow: Measured by pitot tube connected to u-tube manometer in terms of height of water column across the duct at center

Duct: 400mm dia x 2000mm long, ms circular duct for air flow

Head/flow control: baffle/butterfly type of control valve with marking of gate opening

Power input to motor: measured by energy meter connected to ac supply to the motor.

PROCEDURE:

1. Connect the input power for console to 3ph AC supply with neutral and earth.
2. Keep the speed control knob at off
3. Switch on the mains and observe the light indicators are on
4. Keep the inlet valve open fully, set the pitot tube at center of duct, See the pitot tube should face in the direction of flow of air
5. Switch on the green button of ac drive and slowly rotate the speed control knob so that the motor axial fan speed builds up
6. Set the speed of fan to test speed using speed control knob
7. Note down the readings namely, axial fan speed, flow static head (velocity head), energy meter reading for full opening of valves as per the table of readings.
8. Slowly close the valve in steps and note down the readings as mentioned above.

9. After the readings are taken reduce the speed by bring back the speed control knob to zero and press red button and switch off the electrical mains
10. Tabulate the readings and prepare table of calculations using the formulae.

Calculations:

$$\rho_w = \text{Density of water} = 1000 \text{ kg/m}^3$$

$$\rho_a = \text{Density of air at room temperature} = 1.29 \text{ kg/m}^3$$

$$g = \text{Acceleration due to gravity} = 9.81 \text{ m/sec}^2$$

$$A = \text{Area of duct} = (\pi/4) \times D^2 \quad D = 0.4 \text{ m}$$

$$\text{E.M Constant} = \text{Energy meter constant} = 1600 \text{ Imp/KWH}$$

1. Electrical input to AC motor as read on energy meter (Input power)

$$\text{Input power} = \frac{n * 3600}{1600 * t}$$

n = No of revolutions (or) impulse of energy meter

t = Time taken for 'n' revolutions (or) impulse of energy meter

2. Static head developed due to air in the duct

$$H_{sta} = \frac{h_{sta}}{1000} * \left[\frac{\rho_w}{\rho_a} - 1 \right] \text{ meter of air column}$$

$$H_{sta} = 0.744 * h_{sta}$$

Where h_{sta} is the static head developed in mm of water to be read from manometer

3. Volume flow rate

$$Q = \text{Area of duct} \times \text{Velocity of air} = A \times V$$

$$\text{Where } A = 0.074 \text{ m}^2 \quad V = \sqrt{2 * g * H_v}$$

$$H_v = \frac{h_v}{1000} * \left[\frac{\rho_w}{\rho_a} - 1 \right]$$

h_v is the velocity head developed in mm of water to read on U tube manometer

4. Air power calculated from out put of fan (Break power)

$$BP = \frac{\rho_a * g * Q * H_{sta}}{1000}$$

5. Efficiency of the Axial fan

$$\eta = \frac{BP}{IP} * 100$$

6. Iso thermal efficiency

$$\eta_{\text{Isothermal}} = \frac{\eta_{\text{Overall}}}{\text{Input power}} * 100$$

$$\text{Overall efficiency} = \eta_o = \frac{H_{a \text{ inlet}}}{H_{a \text{ outlet}}} * 100$$

$$H_{a \text{ inlet}} = \left[\frac{\rho_w}{\rho_a} \right] * h_{\text{inlet}}$$

$$H_{a \text{ outlet}} = \left[\frac{\rho_w}{\rho_a} \right] * h_{\text{outlet}}$$

$$\text{Input power} = \frac{n * 3600}{1600 * t}$$

Tabular column:

Speed in RPM	Energy meter readings		Static head rise in mm of water ' h _{sta} ' in mm	Velocity head in mm of water 'h _v ' in mm
	n	t		

Table of calculations

Axial fan speed in RPM 'N'	Electrical input in KW	Static pressure rise Meter of air column H_{sta}	Volume flow rate (Q) in M^3/sec	Axial fan out put (BP) in KW	Axial fan efficiency $\% \eta$	Isothermal efficiency η_{iso}

Space For Calculations

RESULT & CONCLUSIONS:

1. Axial fan efficiency $\% \eta$
2. Isothermal efficiency η_{iso}

VIVA QUESTIONS:

1. Define Isothermal Efficiency
2. Differentiate between efficiency and output
3. Define brake power
4. Define indicated power
5. Explain working principal of manometer ?
6. Explain the working principal of Pitot tube ?
7. Explain the working principal of compressor ?
8. Differentiate between compressor and engine ?
9. Define Static Head
10. How to calculate efficiency of flow fan ?

EXPERIMENT - 09

CENTRIFUGAL BLOWER TEST RIG

AIM:

Is to draw the standard performance curves, covering the Head Vs. Flow Rate and Efficiency Vs Flow Rate at constant Speed.

THEORY:

The test rig essentially consists of centrifugal blower handling the air as the medium of flow and is driven by A. C Motor.

The main components are Blower - Motor Unit and Control Console.

- I. The Blower The outlet to the blower is a straight duct of size 248mm x 298mm and 2000mm length and is fixed with Door type of valve at outlet. The pitot tube tapings across duct are connected to Inclined manometers. The tapping for static pressure measurement is also provided at the wall of the duct and connected to double column water manometer.
The speed pick-up is provided for the measurement of RPM of blower and connected to Digital RPM Indicator in front of the Control Console.
- II. The control panel consists of a blower starter, digital speed indicator, fuses, manometers for "FLOW" and "HEAD" (static pressure rise), Energy Meter for electrical input measurement of the motor.
- III. Manometer for measurement of Pressure distribution in blower volute casing at 6 points with valves for pressure at different places. (open one valve at a time for that particular pressure measurement)

Specifications:

- Blower: Type
 - a) Centrifugal with Rectangular Duct of Area (245mx298mm)
= 0.074 m² Area of Duct.
 - b) Backward Curved (Std)
 - c) Speed 1440 rpm (max.)
- Motor:

3 HP A.C. Motor with Step Cone Pulley Arrangement.
Maximum Speed: 0 - 1440 RPM
- Drive:

Belt Driven
- Electrical Input:

3 ph, 415 V, 30A, AC supply

Measurements:

- Speed:
 - By Digital RPM Indicator
- Static Head Rise:
 - Measured downstream of impeller (duct) in terms of height of water column
- Flow:
 - Measured by Pitot Tube connected to Inclined Manometer in terms of height of water column across the duct of area = 0.074 m^2
- Head / Flow Control:
 - Door type of control valve at outlet
- Power Input To Motor :
 - Measured by Energy Meter connected to AC supply to the motor

PROCEDURE:

1. Connect the Input Power for console to 3ph AC supply
2. Keep all the switches / controls OFF /Zero.
3. Connect the transmission belt to one speed (one matching grooves of the motor - blower pulley).
4. Switch ON the mains and observe the light indicators are ON.
5. Keep the inlet and valves open fully.
6. Switch ON the starter so that the motor - blower speed builds up.
7. Take down the readings, namely; blower speed, flow, head, energy meter reading as per the table of readings by operating the outlet valve at different opening. By opening the pressure distribution valves one at a time note down the pressure on manometer of pressure distribution in volute casing.
8. Slowly close the Out let door in steps and note down the readings as mentioned above.
9. After the readings are taken, switch OFF motor trend electrical main.
10. Tabulate the readings and prepare table of calculations using the formulae.

Calculations :

➤ Data Constants:

W_w	= Density of Water	: 1000 kg/m^3
W_a	= Density of Air at 30°C	: 1.29 kg/m^3
	(To be corrected depending on local conditions)	
g	= Acceleration due to gravity	: 9.81 m/sec^2
A	= Area of Duct	: 0.248×0.298 = 0.074 m^2 .
h_p	= One metric home power	: 736 watts.
E.M. Const	= Energy Meter Constant	: 1600 Imp/KWH

I. Electrical Input Power to AC Motor as read on Energy Meter (Input Power)

$$\begin{aligned} IP_{\text{elec}} &= \frac{n}{E.M.Const.} \times \frac{60 \times 60}{t} \\ &= \left[\frac{n}{1600} \times \frac{60 \times 60}{t} \right] \times 0.7 \text{ HP, KW} \text{ --(1)} \end{aligned}$$

Where,

n = No of Revolutions

t = Time taken for 'n' Imp of Energy Meter

EM Constant: 1600 Imp/KWH.

0.7 = 70% considering Efficiency of the Motor & Belt Loses

II. Static Head Developed due to Air in the Duct

$$H_{\text{sta}} = \frac{h_{\text{sta}}}{1000} \times \left[\frac{W_w}{W_a} - 1 \right] \text{ meters of air column} \text{ --(2)}$$

On substitution of W_w , and W_a , we get

$$H_{\text{sta}} = 0.774 h_{\text{sta}}$$

Where,

' h_{sta} ' is the Static Head developed in mm of water to be read from Column - 4.

III. Volume Flow Rate:

$$Q = \text{Area of Duct} \times \text{Air Velocity} \quad \text{m}^3/\text{sec.} \text{ --(3)}$$
$$A \times V$$

Where,

$$A = 0.074 \text{ m}^2$$

$$V = \sqrt{(2gH_v)} \quad \text{m/sec.}$$

$$H_v = \frac{h_v}{1000} \times \left[\frac{W_w}{W_a} - 1 \right] \text{ meters of air column.}$$

Where,

' h_v ' is the Velocity Head developed in mm of water to be read on Inclined manometer.

IV. Air Power calculated from the Output of Blower. (Break Power)

$$BP_{\text{blower}} = \frac{W_a g Q H_{\text{sta}}}{1000} \quad \dots \text{ KW} \text{ --(4)}$$

V. Efficiency of the Blower

$$\% \eta_{\text{blower}} = \frac{BP_{\text{blower}}}{IP_{\text{elec}}} \times 100 \text{ --(5)}$$

Tale of Readings

Energy Meter Constant : Rev/Kwh

S.No	Gate Position	Blower Speed in RMP 'N'	Energy meter Reading		Static Head Rise in mm of Water			Velocity Head in mm of Water h_f	Pressure Distribution in volute Casing									
			"n"	"t"	h_1	h_2	h_{sta}		1		2		3		4		5	
									h_1	h_2	h_1	h_2	h_1	h_2	h_1	h_2	h_1	h_2

Table of calculations

Impeller Type :

S.No	Blower Speed in RMP 'N'	Electrical Input IP_{elec}	Static Pressure Rise Meter Of Air Column H_{sta}	Volume Flow Rate m^3/sec Q	Blower Output Horse Power BP_{blower}	Blower Efficiency $\% \eta_{blower}$	Remarks

Space For Calculations

RESULT & CONCLUSIONS:

Blower efficiency % η

The performance characteristics curves

- a) Volume Flow Rate Vs Head Static Pressure.
- b) Volume Flow Rate Vs Efficiency.

VIVA QUESTIONS:

1. What is the significance of Performance curve ?
2. Differentiate between efficiency and flow rate
3. Define brake power
4. Define indicated power
5. Explain working principal of manometer ?
6. Explain the working principal of Pitot tube ?
7. What are different types of characteristics curve ?
8. Differentiate between Static Head and Pressure Head ?
9. What is the use of energy meter ?
10. Define Horse power ?

EXPERIMENT - 10

Measurement of lift and drag force of models in wind tunnel section

AIM:

To find the measurement of lift and drag force of the models in wind tunnel test section.

THEORY:

In this experiment, we will use a wind tunnel to explore the effect of lift and drag on an airfoil. A fluid flowing past a body, in this case an airfoil has a force exerted on it. Lift is defined to be the component of this force that is perpendicular to the oncoming flow direction. The drag force is the opposite of lift, which is defined to be the component of the fluid-dynamic force parallel to the flow direction. We will explore how the angle of attack changes the amount of lift the airfoil experiences. The angle of attack (α) is the angle between flow and the chord line. The chord line is a straight line between the most forward point and most aft point of the body. We will also study the effects of velocity on lift, if the angle of attack is kept constant and velocity increased we would expect an increase in lift. We will measure the airfoil lift as a function of velocity. The drag coefficient (C_D) and lift coefficient (C_L) are functions of dimensionless parameters such as Reynolds number (Re), Mach number (Ma), Froude number (Fr) and relative roughness of the surface (ϵ/l). The lift and drag coefficients are mostly dependent on the shape of the airfoil, NACA 0012 is a symmetrical airfoil and NACA 4412 is a non-symmetrical airfoil. The shapes play a huge role on the amount of lift and drag generated and will be seen in this experiment. In order to be able to use equations (1),(2) and (3) the velocity needs to be known. This is done by using a pitot-static tube which will be able to make a pressure gradient measurement and then by using the Bernoulli's equation calculate velocity.

PROCEDURE:

Dynamometer Calibration

In order to use the Dynamometer it must be calibrated each time it is used. In order to calibrate the Dynamometer it must be calibrated for the lift and drag measurements. This is done by orientating the measuring device correctly to the calibration fixture and then hanging the appropriate weights from the arm and comparing the meter measurements to the manufactures calibration curves.

Lift Component Calibration

1. Secure the dynamometer to the calibration fixture or clamp the unit to a bench so that the strut and shroud extend beyond the edge of the bench shown in Figure (3).
2. Monitor the output from the **Lift** readout. Adjust the lift LVDT Core Thumbwheel until the voltmeter display reads **0.000**. (See Figure (2). Dynamometer Assembly)
3. Load the **LIFT** beams with known weights equal to the maximum desired operating range (MAX RATING 8lbsf).

4. Remove weights. Verify zero. If necessary adjust the LIFT thumbwheel so that the display reads **0.000**.
5. Reload the weights used in step 3. If necessary adjust the “SPAN” potentiometer. Repeat steps 3 through 5 until “ZERO” is verified.
6. With “ZERO” verified lock the potentiometer setting using the black lock tab on the side of the potentiometer on the meter display.
7. Determine the slope and intercept of the calibration curve by applying decreasing loads of known weights. Record and graphically plot the results of known weight versus digital display. Use the table below for both lift and drag calibration data.

Drag Component Calibration

1. Remount the dynamometer on the calibration fixture so that the drag beams may be gravity loaded (i.e. so that the strut is horizontal) shown in Figure 3.
2. Monitor the output from the **DRAG** readout. Adjust the **DRAG** LVDT thumbwheel until the display reads **0.000**
3. Load the dynamometer with known weights equal to the maximum desired operating range (MAX RATING 5lbsf).
4. Remove weights. Verify zero. If necessary adjust the DRAG thumbwheel so that the display reads **0.000**.
5. Reload the weights used in step 3. If necessary adjust the “SPAN” potentiometer. Repeat steps 3 through 5 until “ZERO” is verified.
6. With “ZERO” verified lock the potentiometer setting.
7. Determine the slope and intercept of the calibration curve by applying decreasing loads of known weights. Record and graphically plot the results of known weight versus digital display.

Table 1: Lift Calibration Table

Applied Mass (g)	Meter Output (mV)

Table 2: Drag Calibration Table

Applied Mass (g)	Meter Output (mV)

Speed Control Instructions

The test section speed is controlled by varying the fan RPM. The wind tunnel is designed to operate in an adjustable speed range from less than 5.0 fps (1.52 m/s) to greater than 50 fps (15.24 m/s). The VFD responds to control signals from the remote keypad.

Operation of Motor (Remote Keypad)

1. Apply power to the inverter (flip switch to on).
2. Enter the desired frequency by using the up and down arrows or the potentiometer knob to scroll to specific frequency.
3. Press the **ENT** button once the desired frequency is achieved. The display will flash between the frequency setting and “FC” indicating that the setting has been made.
4. Press the **RUN** button. The acceleration or deceleration to the new set speed designated by “FC” will be shown on the inverters output. During operation the panel control lamp will flash.
5. Repeat steps 3-5 to change the frequency setting during operation.
6. To stop the motor drive, either enter an operation frequency of 0.0 or press the stop button.

The speed control chart Table (3) was generated by measurements of a pressure gradient using a pitot-static tube and inclined manometer. The velocity has been linearly fitted against frequency Figure (4) any frequency can be selected and the corresponding velocity calculated.

Table 3: Speed Control Chart

Frequency (Hz)	Velocity (ft/s)	Velocity (m/s)
7.5	5.40	1.65
10	7.75	2.36
15	11.84	3.61
20	16.85	5.14
25	22.64	6.9
30	27.06	8.25
35	31.67	9.65
40	35.99	10.97
45	40.26	12.27
50	44.65	13.61
55	49.12	14.97
60	53.55	16.32

There will be two airfoils used in this experiment airfoil NACA 0012 and NACA 4412. To change the angle of attack of the airfoil at constant velocity and record lift and drag measurements. The lift coefficient of an airfoil is directly related to the angle of attack. Increasing the angle of attack is associated with increasing the lift coefficient up to the maximum lift coefficient after which the coefficient decreases. The angle that produces the maximum lift is called the “critical angle of attack” or “stall angle of attack” if the angle is increased past the stall angle then a decrease in the lift coefficient will occur. The critical angle of attack is typically around 15° for many airfoils.

The VFD will be set at 35.0Hz for this experiment.

Table 4: Lift, Drag vs. Angle of Attack (NACA 0012)

<i>Angle of Attack (α)</i>	<i>Lift (N)</i>	<i>Drag (N)</i>
0		
5		
10		
15		
25		
30		
35		

Table 5: Lift, Drag vs. Angle of Attack (NACA 4412)

<i>Angle of Attack (α)</i>	<i>Lift (N)</i>	<i>Drag (N)</i>
0		
5		
10		
15		
25		
30		
35		

To change the velocity while keeping the angle of attack constant. The airfoil will be kept at an angle of attack of 10° and velocity will be ramped from 1 m/s to 15 m/s, measurements of lift and drag will be recorded to Table 6 and Table 7.

Table 6: Lift, Drag vs. Velocity (NACA 0012)

<i>Velocity (m/s)</i>	<i>Frequency (Hz)</i>	<i>Lift (N)</i>	<i>Drag (N)</i>
1			
2			
4			
6			
8			
10			
12			
14			
16			

Table 7: Lift, Drag vs. Velocity (NACA 4412)

Velocity (m/s)	Frequency (Hz)	Lift (N)	Drag (N)
1			
2			
4			
6			
8			
10			
12			
14			
16			

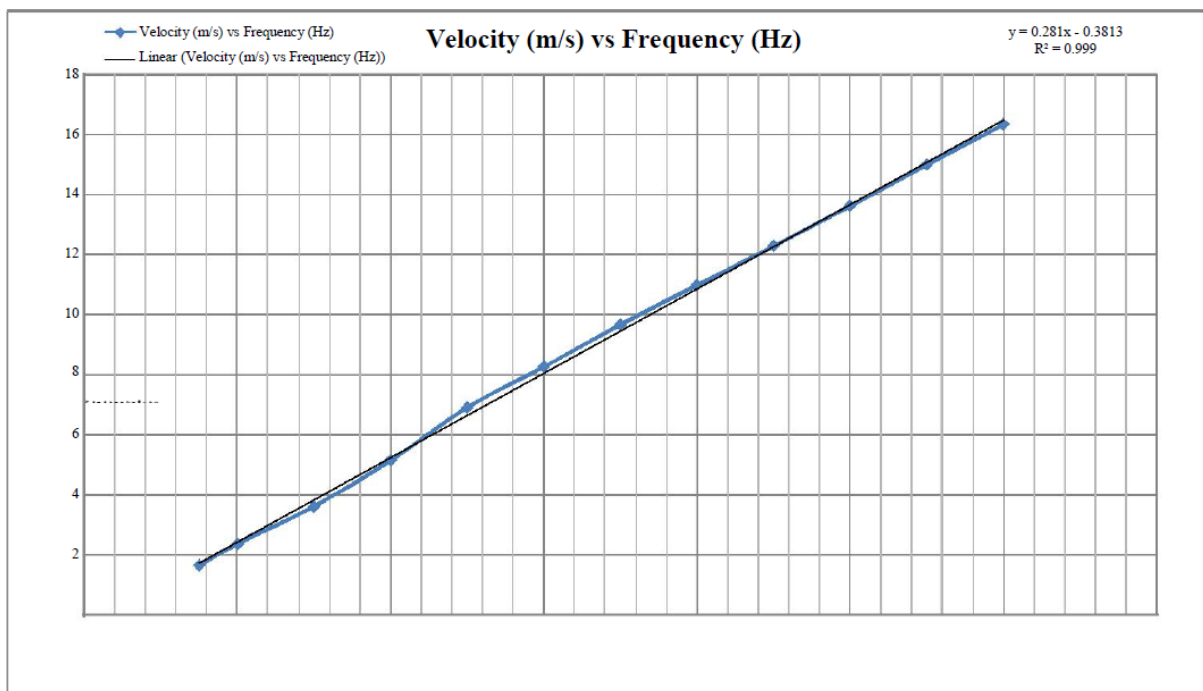

Velocity (m/s) vs. Frequency (Hz)

Calculations

1. The lift is a function of dynamic pressure, surface area and lift coefficient as shown in Equation

$$L=12\rho V^2 A_s C_L \quad (1)$$
2. The drag is a function of dynamic pressure, surface area and drag coefficient as shown in Equation

$$D=12\rho V^2 A_s C_D \quad (2)$$
3. Dynamic Pressure is shown in Equation.

$$Pd=12\rho V^2 (3)$$

4. Surface Area (A_s) is a function of the chord and span and is shown in Equation (4).

$$AS=cl (4)$$

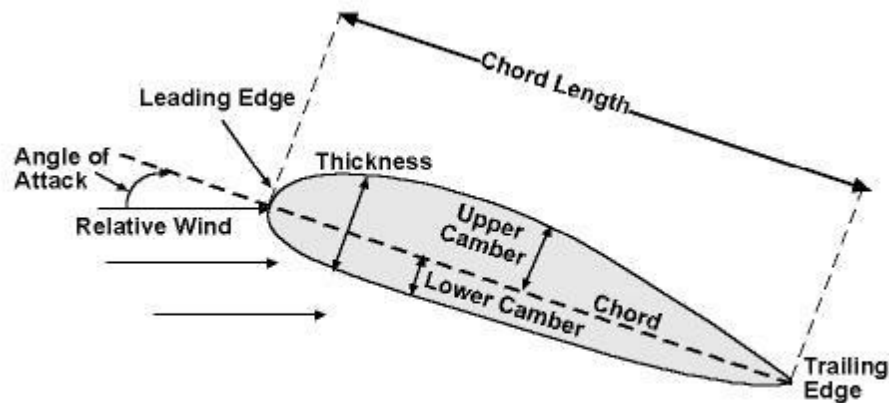

Airfoil Nomenclature

5. Bernoulli's Equation is a function of pressure, density, velocity and specific weight and is shown in Equation.

$$P_1 + \frac{1}{2} \rho V_1^2 + \gamma z_1 = P_2 + \frac{1}{2} \rho V_2^2 + \gamma z_2 (5)$$

6. Assuming if $z_1=z_2$, meaning the heights are at the same level then the equation can be written as Equation (6) which then can be rearranged into Equation (7) which is the velocity along the streamline.

$$\Delta P = \frac{1}{2} \rho V^2 (6)$$

$$V = \sqrt{2 \frac{\Delta P}{\rho}} (7)$$

Space For Calculations

RESULT & CONCLUSIONS:

1. NACA 0012

Lift :
Drag :
Velocity :
Frequency :

2. NACA 4412

Lift :
Drag :
Velocity :
Frequency :

VIVA QUESTIONS:

1. What is the stall angle for airfoil NACA 0012 and NACA 4412?
2. Why do you suppose the stall angles are different?
3. Why is NACA 0012 classified as a symmetric airfoil and NACA 4412 as a nonsymmetrical airfoil?
4. How does the symmetric and non-symmetric airfoils compare in lift and drag at a fixed angle of attack?
5. Would you expect the performance of the NACA 0012 to be the same if it was flipped over?
6. How about the NACA 4412 airfoil?
7. Why is it that an airplane can fly upside down?
8. What must a pilot do in order for it to do so?
9. Why is it in an open cockpit when the pilot performs a loop or vector roll he doesn't fall out?
10. What type of flow field is experienced by the airfoil in the experiment laminar or turbulent?
11. What is turbulence?
12. What effect does it have on an airfoil?

EXPERIMENT - 10

Pressure distributions over a symmetrical & non symmetrical specimen in wind tunnel

AIM

To determine the Pressure Co-efficient on Symmetrical specimen at different values of angles of attack.

APPARATUS REQUIRED

Subsonic wind tunnel
Pressure distribution tube
Symmetrical specimen

FORMULA

$$C_p(i) = \frac{P_{13} - P_i}{\sqrt{2}} / P_o - P$$

Where,

$P_{13} = P_i$ = static pressure in cm [from Manometer 13th point]

P_i = pressure at each point in cm

$P_o - P$ = initial Manometer reading in cm

PROCEDURE

1. Initially switch ON the power supply and then the reside is one condition.
2. Warm up the subsonic wind tunnel for about 10 minutes in order to obtain the accurate values.
3. By turning the AC motor adjust the speed of the air in the air speed indicator, which is required for our experiments.
4. Place the symmetric specimen in zero angle of attack and then note the corresponding values of locations 1 to 13 in pressure distribution tubes.
5. Change the specimen angle of 5° and then again note the corresponding values in the pressure distribution tubes.
6. Follow the same procedure for different angles in the symmetric airfoil.
7. Tabulate the readings and calculate pressure for each angles.
8. Plot the graph by using the pressure distribution on symmetric airfoil to the pressure in mm of water.

Value of pressure co-efficient on symmetrical specimen

S. no	Locations	Angle of attack in degree [Initial Manometer Reading =6cm]													
		$C_p(i)$	0	$C_p(i)$	5	$C_p(i)$	10	$C_p(i)$	15	$C_p(i)$	-5	$C_p(i)$	-10	$C_p(i)$	-15

RESULT

Thus the pressure distribution over symmetric specimen is calculated.

Pressure distributions over a non symmetrical specimen in wind tunnel

AIM

To determine the pressure co-efficient of unsymmetrical airfoil at different values of angle of attack.

APPARATUS REQUIRED

Subsonic wind tunnel
Pressure distribution tube
Unsymmetrical specimen

FORMULA

$$C_p(i) = \frac{P_{13} - P_i}{\sqrt{2}} / P_o - P$$

Where,

$P_{13} = P_i$ = static pressure in cm [from Manometer 13th point]

P_i = pressure at each point in cm

$P_o - P$ = initial Manometer reading in cm

PROCEDURE

1. Initially switch ON the power and then turn the consider is one condition.
2. Warm up the subsonic wind tunnel for about 10 minutes in order to obtain the indicator which is required for our experiments.
3. By turning the AC motor adjust the speed of the air in the air speed of the air in the air speed indicator which is required for our experiments.
4. Place the un-symmetrical specimen in zero angle of attack and then note the corresponding values in locations 1 to 13 in pressure distribution tubes.
5. Change the un-symmetrical specimen angle to 5° and then again note the corresponding values in the pressure distribution tubes.
6. Follow the same procedure for different angle in the un-symmetrical specimen
7. Tabulate the reading and calculate pressure for each angle.
8. Plot the graph by using the pressure distribution for each angle on un-symmetrical specimen to the pressure in mm of water.

Values of pressure co-efficient on un-symmetrical specimen

S. no	Locat-ions	Angle of attack in degree [Initial Manometer Reading =6.5cm]													
		$C_p(i)$	0	$C_p(i)$	5	$C_p(i)$	10	$C_p(i)$	15	$C_p(i)$	-5	$C_p(i)$	-10	$C_p(i)$	-15

RESULT

Thus the pressure distribution over un-symmetric airfoil is calculated.

Viva questions:

1. Is C_p defined or derived?
2. What is the limit of C_p value?
3. Does the shape and the size of the pressure taps cause any errors?
4. Can the pressure taps be elliptic or square in shape?
5. After which Reynolds number, there exists a potential difference between the theory and experimental results?
6. Is there any effect on location of the static pressure taps in the same cross section?
7. What is the error involved in computing C_l from C_p distribution?
8. Can the pressure taps be elliptic or square in shape?
9. Is the C_l vs α plot same for all the Reynolds numbers? How does the C_l vary as the Reynolds number is increased? Reason out for the above behavior.
10. Compare the data from NACA reports for the given airfoil
11. What is the stall?
12. Is the maximum lift coefficient same in the case of all Reynolds numbers?

EXPERIMENT - 11

HEAT TRANSFER IN NATURAL CONVECTION

AIM:

To determine the heat transfer coefficient for the surface of the tube in both vertical and horizontal position by natural convection.

THEORY:

When a hot body is kept in still atmosphere, heat is transferred to the surrounding fluid by natural convection. The fluid layer in contact with the hot body gets heated; rise up due to the decrease in its density and the cold fluid rushes in to take place. The process is continuous and the heat transfer takes place due to the relative motion of hot cold fluid particles.

The heat transfer coefficient is given by

$$h = \frac{q - q_1}{A_s * (T_s - T_A)}$$

If heat loss by radiation is neglected

$$h = \frac{q}{A_s * (T_s - T_A)}$$

Where, h = Average surface heat transfer coefficient (W/ m²°C)

q = Heat transfer rate (Watts)

As = Area of heat transferring surface = $\pi \cdot d \cdot l$ (m²)

T_s = Average surface temperature = $\frac{T_1+T_2+T_3+T_4}{4}$ °C

T_a = Ambient temperature = T₅ °C

q₁ = Heat loss by radiation = $\sigma * A * \epsilon * (T_s^4 - T_A^4)$

Where, σ = Stefan Boltzmann constant = 5.667×10^{-8} W/m².K⁴

A = Surface area of pipe = $(0.05966) \text{ m}^2 = \pi D L$

ϵ = Emissive of pipe material = 0.6

T_s and T_a Surface and ambient temperatures in °K respectively

The surface heat transfer coefficient, of a system transferring heat by natural convection depends on the shape, dimensions and orientation of the fluid and the temperature difference between heat transferring surface and the fluid. The dependence of 'h' on all the above-mentioned parameters is generally expressed in terms on non-dimensional groups as follow

$$\frac{h * l}{k} = A * \left[\frac{g * L^3 * \beta * \Delta T}{\nu^2} * \frac{C_p * \mu}{K} \right]$$

Where,

$\frac{h * l}{k}$ is called the Nusselt number,

$\frac{g * L^3 * \beta * \Delta T}{\nu^2}$ is called to Grashof Number and

$\frac{C_p * \mu}{K}$ is the Prandtl Number

A and n are constants depending on the shape and orientation of the heat transferring surface.

Where,

L = A characteristic dimension of the surface.

K = Thermal conductivity of fluid.

ν = Kinematics Viscosity of fluid.

μ = Dynamic Viscosity of fluid.

C_p = Specific heat of fluid.

β = Coefficient of volumetric expansion for the fluid.

g = Acceleration due to gravity.

$\Delta T = [T_s - T_a]$

For gases,

$$\beta = \frac{1}{T_f + 273} \text{ } ^\circ K$$

$$T_f = \frac{T_s + T_a}{2} \text{ } ^\circ K$$

Where T_f film temperature

For a vertical cylinder losing heat by natural convection, the constant A and n of equation(2) have been determined and the following empirical correlation obtained.

For horizontal position

$$\frac{h^*l}{k} = 0.54 * (Gr * Pr)^{0.25} \quad \text{for } 10^4 < Gr * Pr < 10^8$$

$$\frac{h^*l}{k} = 0.13 * (Gr * Pr)^{0.333} \quad \text{for } 10^8 < Gr * Pr < 10^{12}$$

For Vertical position

$$\frac{h^*l}{k} = 0.59 * (Gr * Pr)^{0.25} \quad \text{for } 10^4 < Gr * Pr < 10^8$$

$$\frac{h^*l}{k} = 0.13 * (Gr * Pr)^{0.333} \quad \text{for } 10^8 < Gr * Pr < 10^{12}$$

L = Length of the cylinder. = 500mm

All the properties are determined at the mean film temperature (T_f). from Data book

Specification:

1. Diameter of the tube (d) = 38 mm
2. Length of tube (L) = 500 mm
3. Multichannel Digital Temperature Indicator.
4. Ammeter 0 – 2 Amp.
5. Voltmeter 0 – 200 Volts.
6. Dimmerstat 2 Amp. 240 Volts.
7. Heater :400watts
8. Thermocouples : 5

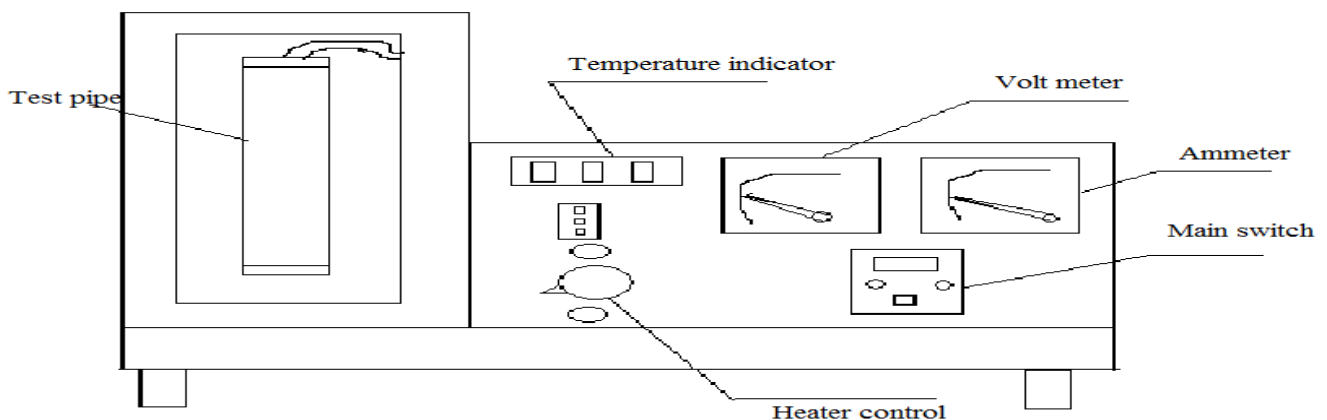

FIG: NATURAL CONVECTION APPARATUS

PROCEDURE:

1. Put ON the supply and adjust the dimmerstat to obtain the required heat input – (Say 40W, 60W, 70W etc)
2. Wait till the steady state is reached, which is confirmed from temperature reading- (T₁ to T₇)
3. Measure surface temperature at the various point i.e. T₁ to T₇.
4. Note the ambient temperature i.e. T₈.
5. Repeat the experiment at different heat inputs (Do not exceed 80w).

Observations

1. O. D. Cylinder = 38mm.
2. Length of cylinder = 500mm.
3. Input to heater Q= V x I Watts.

Tabular column :

S.NO	V	I	Q=V*I	T1	T2	T3	T4	T5	h theory	h Expt
1										
2										
3										
4										

Calculations:

- 1) Calculate the value of average surface heat transfer coefficient, for vertical and horizontal positions

$$h = \frac{q}{A_s * (T_s - T_A)}$$

- 2) Compare the experimentally obtained value with the prediction of the correlation equations .

Note – The heat loss due to radiation and conduction is not considered, but they are present, which give different between actual and theoretical values.

Space For Calculations

RESULT & CONCLUSIONS:

Heat Transfer coefficient for a vertical tube losing heat by natural convection is found out to be

1) Experimentally $h = \frac{W}{m^2k}$
2) Theoretically $h = \frac{W}{m^2k}$

Heat Transfer coefficient for a Horizontal tube losing heat by natural convection is found out to be

1) Experimentally $h = \frac{W}{m^2k}$
2) Theoretically $h = \frac{W}{m^2k}$

VIVA QUESTIONS:

1. What is convection?
2. Classify convection.
3. What is forced convection & natural convection?
4. Explain difference between forced convection and natural convection?
5. On which properties does convection heat transfer strongly depend?
6. Define convection heat transfer coefficient with dimensions.
7. Define Nussult number.
8. Develop velocity boundary layer for flow over a flat plate?
9. The Prandtl number will be lowest for-----
10. What is significance of Nussult's number in convection?
11. The hydro dynamic and thermal boundary layers are identical at Prandtl number equal to-----
12. The temperature gradient in the fluid flow over a heated plate will be-----
13. The ratio of heat transfer by convection to that by conduction is called-----
14. Define buoyancy force and discuss significance of the buoyancy force in Natural convection?
15. Define volume expansion coefficient and discuss significance in Natural convection?
16. Define Grashoff number and discuss significance of Grashoff number?
17. The free convection heat transfer is significantly affected by----
18. The convective heat transfer coefficient from a hot cylindrical surface exposed to still air varies in accordance with-----
19. For Laminar conditions, the thickness of thermal boundary layer increases with the distance from the leading edge in proportion to-----

EXPERIMENT - 12

HEAT TRANSFER IN FORCED CONVECTION

AIM:

To determine the heat transfer coefficient in forced convection.

THEORY:

In many practical situations and equipments, we invariably deal with flow of fluids in tubes e.g. boiler, super heaters and condensers of a power plant, automobile radiators, water and air heaters or coolers etc. the knowledge and evolution of forced convection heat transfer coefficient for fluid flow in tubes is essentially a prerequisite for an optional design of all thermal system

Convection is the transfer of heat within a fluid by mixing of one portion of fluid with the other. Convection is possible only in a fluid medium and is directly linked with the transport of medium itself.

In forced convection, fluid motion is principally produced by some superimposed velocity field like a fan, blower or a pump, the energy transport is said due to forced convection.

The apparatus consists of a blower unit fitted with the test pipe. The test section is surrounded by a Nichrome band heater. Three thermocouples are embedded on the test section and two thermocouples are placed in the air stream at the entrance and exit of the test section to measure the air temperature. Test pipe is connected to the delivery side of the blower along with the orifice to measure flow of air through the pipe. Input to the heater is given through a dimmerstat.

It is to be noted that only a part of the total heat supplied is utilized in heating the air. A temperature indicator is provided to measure temperatures of pipe wall at various points in the test section. Airflow is measured with the help of orifice meter and the water manometer fitted on the board.

Specification:

Pipe diameter (D_o) : 38 mm

Length of test section (L) : 500 mm

Orifice Diameter (d) : 10 mm

Dimmer stat : 0 to 2 amp, 230 volt, AC

Diameter of the pipe (D_o) = 38 mm

Length of the test section (L) = 500 mm

Diameter of the orifice (d) = 10 mm

Temperature indicator : Digital type and range 0 - 200 °c

Voltmeter : 0 -100 /200v

Ammeter : 0 – 2 amp

Heater : Nichrome wire heater wound on Test Pipe (Band Type) 500 watt

T1:- Air Inlet Temperature

T5:- Air Outlet Temperature

T2 ,T3&- T4:- Pipe Wall Temperature

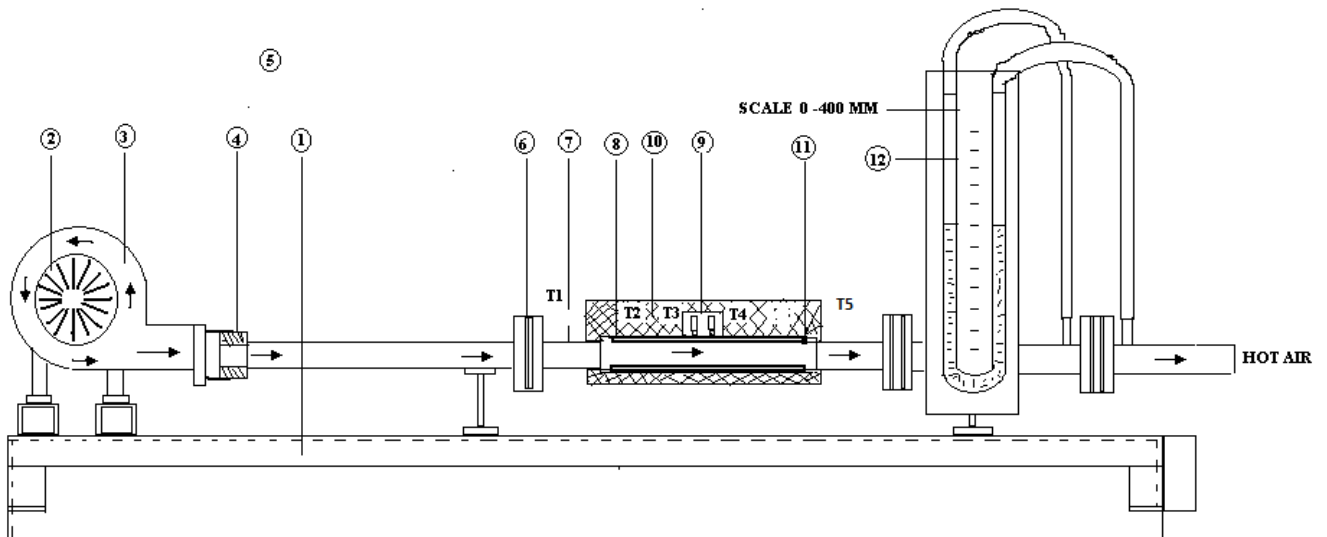

FIG: FORCED CONVECTION APPARATUS

- 1)Table 2) Motor 3) Blower 4) Adapter 6) Orifice 7) Air Inlet Temperature
8) Mica Covered Heater 9) Heater Socket 10) Foam Packing 11) Stainless Steel Cladding
12) Monometer

PROCEDURE:

1. Switch ON the mains system
2. Switch ON blower.
3. Switch ON heater
4. Start the heating of the test section with the help of dimmerstat and adjust desired heat input with the help of Voltmeter and Ammeter. Say 60volts ,70volts etc
5. Take readings of all the six thermocouples at an interval of 10 min until the steady state is reached.

Tabular column:

S. NO	V (Volts)	I (Amps)	Q=V*I Watts	Temperature in °c					Manometer reading of water H in meter	
				T ₁ °C	T ₂ °C	T ₃ °C	T ₄ °C	T ₅ °C	H ₁	H ₂
1										
2										
3										
4										

Calculation:

1) A_o = Area of Cross Section Orifice in m²

$$A_o = \frac{\pi}{4} D^2$$

d=dia of orifice=10mm

2) Q = Volume flow rate in m³ / sec

$$Q = C_d * A_o * \sqrt{2 * g * h * \frac{\rho_w}{\rho_a}}$$

Where,

C_d = Coefficient of discharge of orifice = 0.68

A_o = area of cross section of orifice in m²

ρ_w = Density of water = 1000 Kg/m³

ρ_a = density of air at ambient temp. = 1.03 Kg/m³

H = manometer reading in meter = H₁- H₂

3) M_a = mass flow rate of air in Kg / sec

$$M_a = Q * \rho_a$$

Where

ρ_a = Density of air at Ambt. temp. = 1.03 Kg/m³

4) Δ_T = Temperature rise in air in °C or °K

$$\Delta_T = (T_5 - T_1)$$

5) Q_a = Heat carried away by Air in kJ / sec or Watts

$$Q_a = m_a * C_p * \Delta T$$

Where,

C_p = specific heat of air= 1.005 KJ / Kg °K

6) T_a = Average Temperature of Air in °C

$$T_a = \frac{T_1 + T_5}{2}$$

7) T_s = Average Surface Temperature in °C

$$T_s = \frac{T_2 + T_3 + T_4}{3}$$

8) A = Test Section Surface Area in m^2

$$A = \pi * D_i * L$$

Where,

D_i = Inner diameter of the test pipe in meter

L = Length of the test section in meter

9) h = Heat Transfer Coefficient in $\frac{W}{m^2K}$

$$h = \frac{Q}{A * (T_s - T_a)} \frac{W}{m^2K}$$

Theoretical calculations:

1) A_c = Cross Test Section Area in m^2

$$A_c = \frac{\pi}{4} D_i^2$$

2) V = Mean Velocity of Flow through tube in $\frac{m}{sec}$

$$V = \frac{Q}{A_c}$$

3) Re = Reynold's Number

$$Re = \frac{V D}{\nu}$$

Where,

ν = Kinematic Viscosity in (m^2/s) at bulk mean

Temp. i.e.

$$\frac{T_1 + T_5}{2}$$

Pr = Prandtl Number

4) Pr = 0.7 at Avg. Temperature

5) Nu = Nusselt Number

$$Nu = 0.023 * Re^{0.8} * Pr^{0.3}$$

h = heat transfer coefficient calculated by using the correlations

$$Nu = 0.26 Re^{0.6} Pr^{0.33} \dots\dots\dots \text{For } Re < 2300 \text{ (Laminar flow)}$$

$$Nu = 0.023 Re^{0.8} Pr^{0.33} \dots\dots\dots \text{For } Re > 2300 \text{ (turbulent flow)}$$

$$NU = \frac{hD}{K}$$

Where,

K = thermal conductivity of air at avg. temp. in -----

Precautions

1. Keep the dimmer stat at zero position before switching ON the power supply.
2. Increase the voltmeter gradually.
3. Do not stop the blower in between the testing period.
4. Do not disturb thermocouples while testing. Operate selector switch of the thermocouple gently. Don't exceed 200 watts
5. Operate selector switch of the temperature indicator gently.

Space For Calculations

RESULT & CONCLUSIONS:

Heat transfer coefficient in forced convection of air in a tube is found out to be
experimentally ----- $\frac{w}{m^2k}$

Heat transfer coefficient in forced convection of air in a tube is found out to be
Theoretically ----- $\frac{w}{m^2k}$

VIVA QUESTIONS:

1. What is convection?
2. Classify convection.
3. What is forced convection & natural convection?
4. Explain difference between forced convection and natural convection?
5. Force convection in a liquid bath is caused by----
6. Explain Newton's law of cooling?
7. Give the relation between 'Fluid velocity' and 'Heat transfer'?
8. On which properties does convection heat transfer strongly depend?
9. Define convection heat transfer coefficient with dimensions.
10. Define Nussult number.
11. Develop velocity boundary layer for flow over a flat plate?
12. What is drag force?
13. Define friction coefficient (or) drag coefficient?
14. Explain Reynolds number?
15. What is critical Reynolds number?
16. Explain Prandtl number.
17. Fluid properties are evaluated at what temperature?
18. For forced convection, Nussult number is a function of-----
19. The Prandtl number will be lowest for-----
20. What is significance of Nussult's number in convection?
21. The hydro dynamic and thermal boundary layers are identical at Prandtl number equal to-----
22. The temperature gradient in the fluid flow over a heated plate will be-----
23. The ratio of heat transfer by convection to that by conduction is called-----
24. What is significance of Stanton number?
25. The convective heat transfer coefficient from a hot cylindrical surface exposed to still air varies in accordance with-----
26. For Laminar conditions, the thickness of thermal boundary layer increases with the distance from the leading edge in proportion to-----
27. Which dimensionless number has a significant role in forced convection?



Estd: 2008

METHODIST

COLLEGE OF ENGINEERING & TECHNOLOGY

Approved by AICTE New Delhi | Affiliated to Osmania University, Hyderabad

Abids, Hyderabad, Telangana, 500001